



US008000010B2

(12) **United States Patent**
Crandall

(10) **Patent No.:** **US 8,000,010 B2**
(45) **Date of Patent:** **Aug. 16, 2011**

(54) **SIGHTING OPTICS INCLUDING AN OPTICAL ELEMENT HAVING A FIRST FOCAL LENGTH AND A SECOND FOCAL LENGTH AND METHODS FOR SIGHTING**

6,360,471 B1 3/2002 Stein
6,881,947 B2 4/2005 Mitsuoka et al.
6,982,840 B1 1/2006 Schlieff
7,069,684 B2 7/2006 Smith, III
2002/0066220 A1 6/2002 Malley
2010/0238554 A1* 9/2010 Crandall 359/565

(75) Inventor: **David Lynn Crandall**, Idaho Falls, ID (US)

FOREIGN PATENT DOCUMENTS

DE 3102976 A1 * 8/1982

(73) Assignee: **Battelle Energy Alliance, LLC**, Idaho Falls, ID (US)

OTHER PUBLICATIONS

(*) Notice: Subject to any disclaimer, the term of this patent is extended or adjusted under 35 U.S.C. 154(b) by 729 days.

D. J. Stigliani, R. Mitra, R. G. Semonin, 'Resolving power of a zone plate', J. Opt. Soc. Am., vol. 57, No. 5, May 1967, pp. 610-613.*
M. Young, 'Zone plates and their aberrations', J. Opt. Soc. Am., vol. 62, No. 8, Aug. 1972, pp. 972-976.*
Zone plate, http://en.wikipedia.org/wiki/Zone_plate, retrieved Oct. 4, 2010.*
International Search Report and Written Opinion of the International Searching Authority, International Application No. PCT/US07/74877, International Filing Date Jul. 31, 2007.
English translation of DE 3102976 A1, dated Aug. 5, 1982 to Barchilon (13 pages).

(21) Appl. No.: **11/831,581**

(22) Filed: **Jul. 31, 2007**

(65) **Prior Publication Data**

US 2010/0024275 A1 Feb. 4, 2010

* cited by examiner

(51) **Int. Cl.**
G02B 5/18 (2006.01)

Primary Examiner — Arnel C Lavarias

(52) **U.S. Cl.** **359/569**; 359/574; 42/111

(74) *Attorney, Agent, or Firm* — TraskBritt

(58) **Field of Classification Search** None
See application file for complete search history.

(56) **References Cited**

(57) **ABSTRACT**

U.S. PATENT DOCUMENTS

2,679,474 A * 5/1954 Pajes 205/149
5,017,000 A 5/1991 Cohen
5,148,314 A 9/1992 Chen
5,446,588 A 8/1995 Missig et al.
5,969,864 A * 10/1999 Chen et al. 359/569
6,104,533 A * 8/2000 Clark et al. 359/566
6,336,285 B1 1/2002 Baumer

Sighting optics include a front sight and a rear sight positioned in a spaced-apart relation. The rear sight includes an optical element having a first focal length and a second focal length. The first focal length is selected so that it is about equal to a distance separating the optical element and the front sight and the second focal length is selected so that it is about equal to a target distance. The optical element thus brings into simultaneous focus for a user images of the front sight and the target.

11 Claims, 4 Drawing Sheets

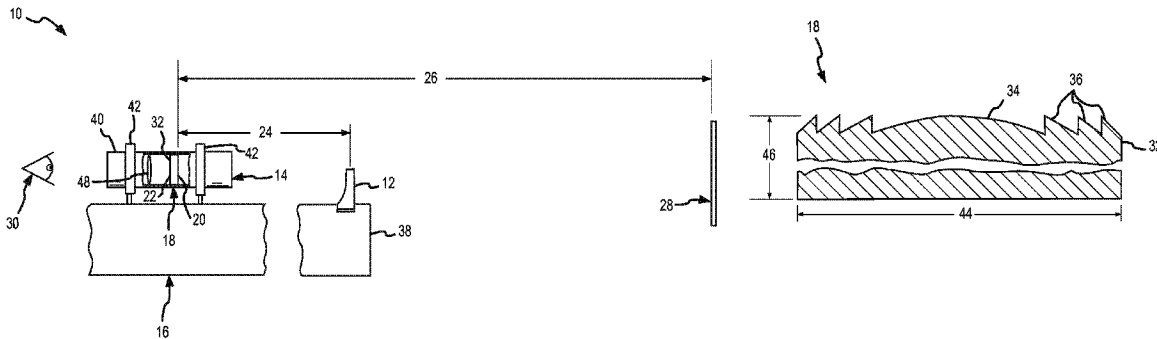

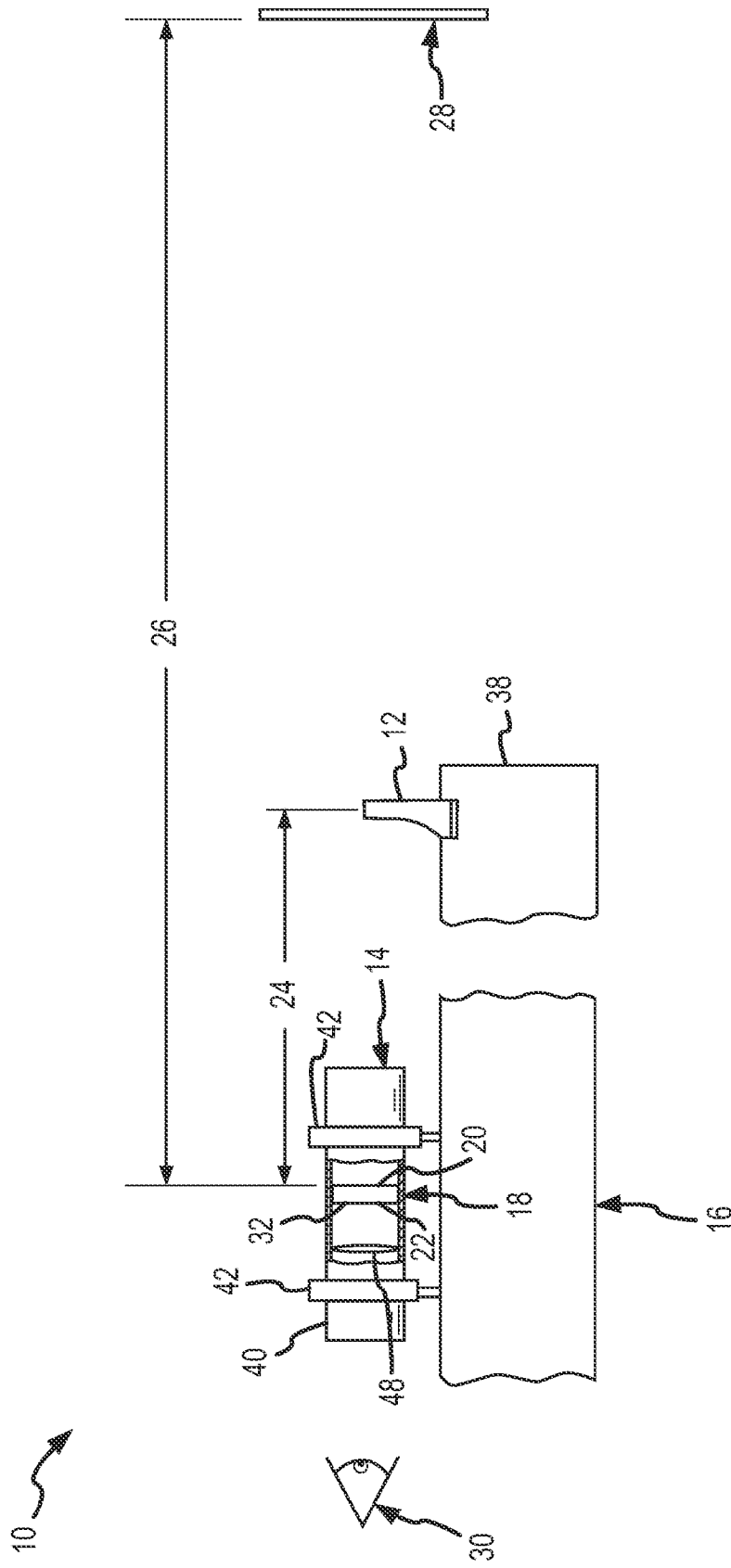

FIG.1

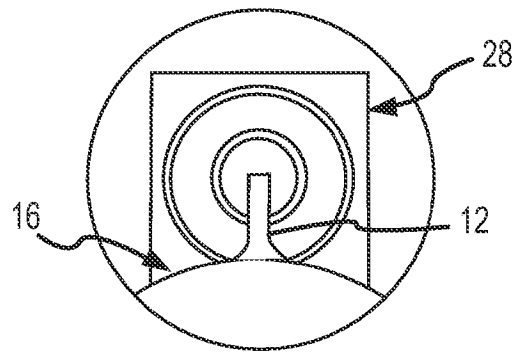

FIG. 2

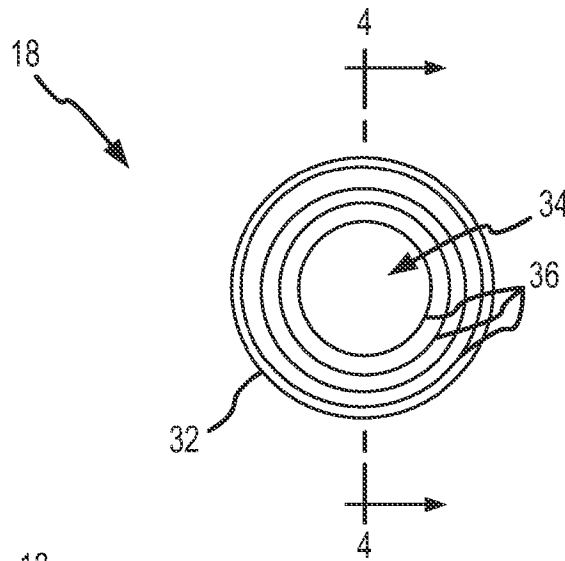

FIG. 3

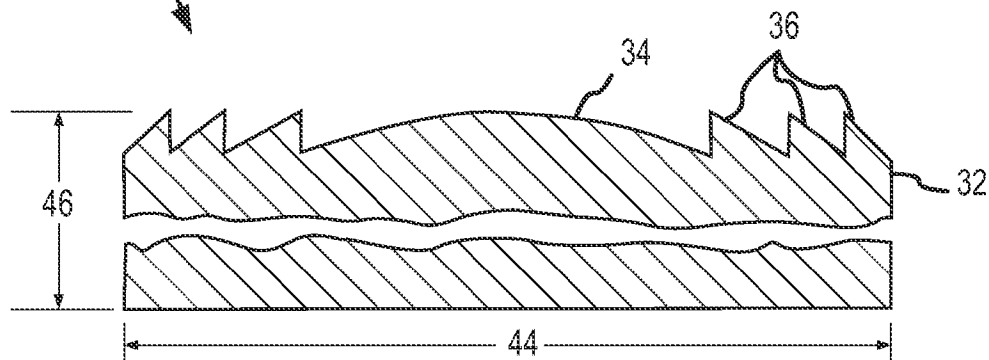

FIG. 4

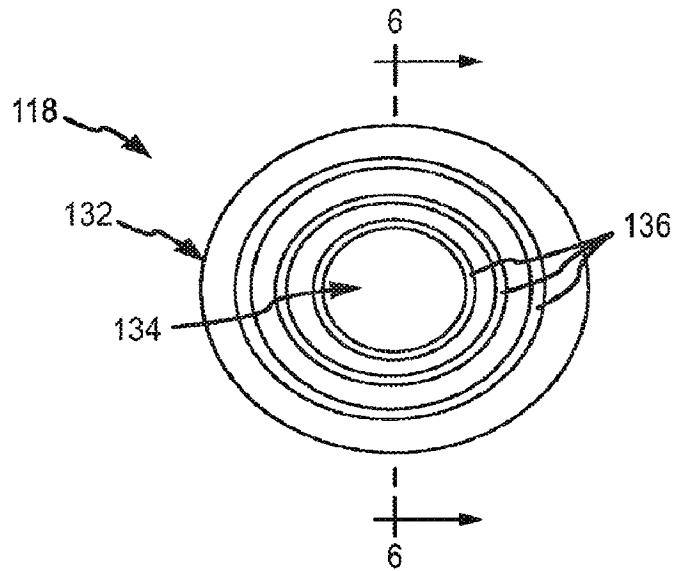

FIG. 5

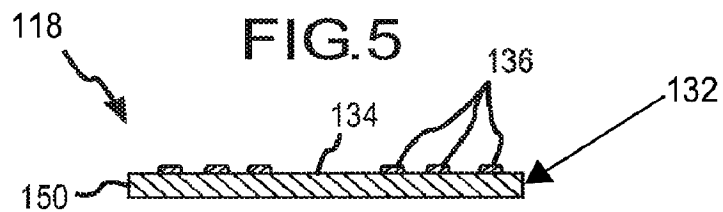

FIG. 6

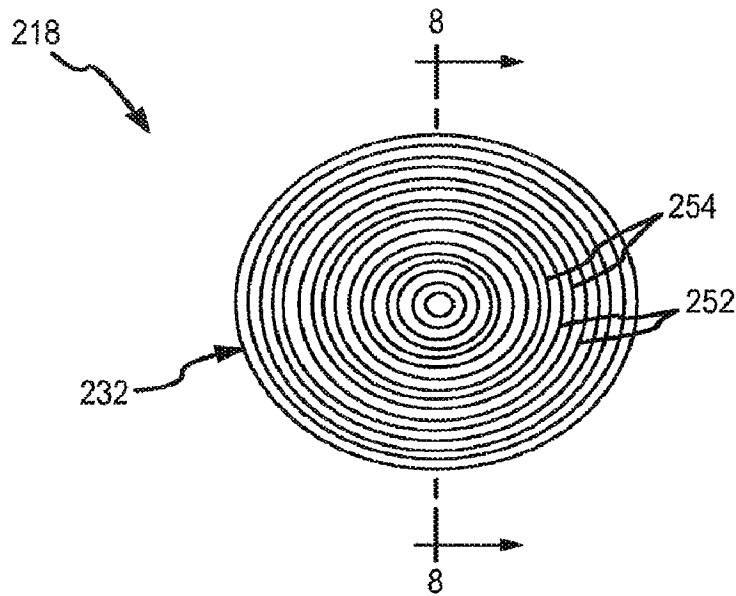

FIG. 7

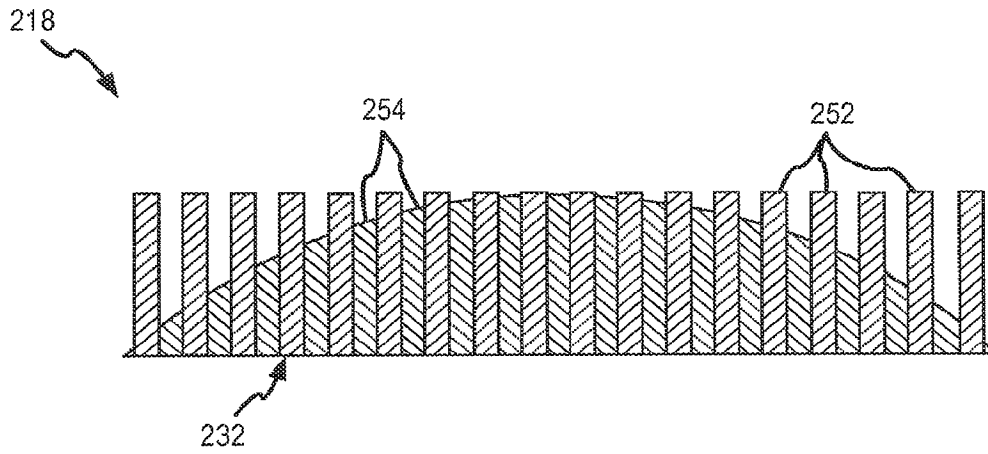

FIG. 8

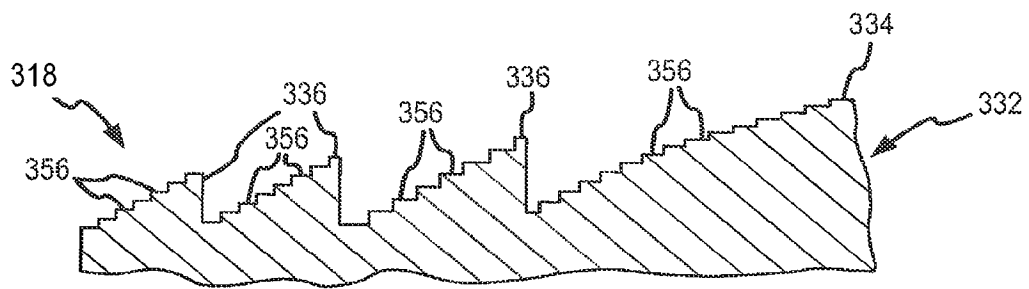

FIG. 9

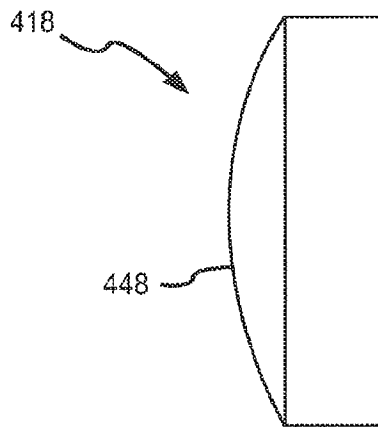

FIG. 10

1

**SIGHTING OPTICS INCLUDING AN
OPTICAL ELEMENT HAVING A FIRST
FOCAL LENGTH AND A SECOND FOCAL
LENGTH AND METHODS FOR SIGHTING**

GOVERNMENT RIGHTS

This invention was made with government support under Contract No. DE-AC07-05-ID14517 awarded by the United States Department of Energy. The government has certain rights in the invention.

CROSS-REFERENCE TO RELATED
APPLICATION

This application is related to copending U.S. patent application Ser. No. 12/785,892, filed May 24, 2010, which is a divisional of the present application.

TECHNICAL FIELD

This invention relates to sighting optics in general and, more specifically, to sighting systems for weapons.

BACKGROUND

Many different types of sighting systems are known in the art and are used to assist in the aiming of a variety of devices, typically those used to launch projectiles, such as firearms and bows, although they are used in other applications as well. Perhaps the simplest and most rugged type of sighting system is the so-called "iron sight," which refers to the open, unmagnified aiming system typically used on firearms. An iron sight usually comprises a front sight and a rear sight. The front sight may take the form of a post, bead, or ring-shaped structure, whereas the rear sight may take the form of a notch or aperture. The rear sight is often made adjustable to allow a user to more easily compensate for wind or elevation, although in some applications the front sight is also adjustable.

Iron sights work by providing horizontal and vertical reference points that allow the user to align the weapon with the intended target. Once the front and rear sights are aligned with one another, they are placed in correct relation to the target. However, since the human eye is only capable of focusing at one distance at any given time, it is not possible for a user to focus simultaneously on the front sight and the target. As a result, the aiming process is degraded. That is, the user must first focus on the front sight in order to align the front and rear sights. The user must then re-focus on the target and then place the now out of focus front sight on the target. Because the front sight is out of focus, it is difficult to place the front sight at the precise position in relation to the target to produce a hit.

While telescopic sights represent an improvement over iron sights in that the target and reticle are simultaneously focused for the user, telescopic sights are expensive, heavy, relatively bulky, and easily subject to damage and/or misalignment due to rough handling. As a result, telescopic sights are typically limited to applications where cost and weight are not significant issues and where proper care can be exercised to avoid damage and/or misalignment.

SUMMARY

Sighting optics according to one embodiment of the invention may comprise a front sight and a rear sight positioned in

2

a spaced-apart relation. The rear sight includes an optical element having a first focal length and a second focal length. The first focal length is selected so that it is about equal to a distance separating the optical element and the front sight, whereas the second focal length is selected so that it is about equal to a target distance. The optical element thus brings into simultaneous focus, for a user, images of the front sight and the target.

Also disclosed is a method for sighting that includes providing a front sight on a device to be sighted, positioning an optical element with respect to the front sight so that the optical element is located between the front sight and a user's eye when the device is in an operative position with respect to the user, viewing the front sight and the target through the optical element, the optical element bringing into substantially simultaneous focus the front sight and the target, and moving the device so that the front sight is in a desired relation to the target.

BRIEF DESCRIPTION OF THE DRAWINGS

Illustrative embodiments of the invention are shown in the accompanying drawings in which:

FIG. 1 is a schematic representation of one embodiment of sighting optics as the sighting optics could be utilized on a gun barrel;

FIG. 2 is a schematic representation of a view looking through sighting optics showing substantially simultaneously focused images of a front sight and a target;

FIG. 3 is a front view in elevation of a first embodiment of an optical element showing a central area and surrounding rings;

FIG. 4 is an enlarged cross-sectional view in elevation of the first embodiment of the optical element taken along section line 4-4 of FIG. 3;

FIG. 5 is a front view in elevation of a second embodiment of an optical element;

FIG. 6 is an enlarged cross-sectional view in elevation of the second embodiment of the optical element taken along section line 6-6 of FIG. 5;

FIG. 7 is a front view in elevation of a third embodiment of an optical element;

FIG. 8 is an enlarged cross-sectional view in elevation of the third embodiment of the optical element taken along section line 8-8 of FIG. 7;

FIG. 9 is an enlarged cross-sectional view in elevation of a portion of a fourth embodiment of an optical element; and

FIG. 10 is a side view in elevation of a fifth embodiment of an optical element.

DETAILED DESCRIPTION

Sighting optics 10 according to one embodiment of the present invention are best seen in FIGS. 1 and 2 and may comprise a front sight 12 and a rear sight 14. Front sight 12 and rear sight 14 may be mounted in a spaced-apart relation on a suitable sighting platform, such as a gun barrel 16, although other arrangements are possible, as will be described in further detail below. Rear sight 14 may comprise an optical element 18 having a first focal length and a second focal length. As used herein, the term "focal length" refers to the distance at which an object located on an object side 20 of optical element 18 will be substantially brought into focus (as a virtual image) at a defined location (e.g., to a user's eye 30) on an image side 22 of optical element 18. Because optical element 18 is provided with first and second focal lengths, optical element 18 is capable of bringing into substantially

simultaneous focus, virtual images of objects located at two different positions (i.e., the first focal length and the second focal length) on the object side **20** of optical element **18**.

In the embodiment illustrated in FIGS. **1** and **2**, the first focal length of optical element **18** is selected so that it is about equal to a distance **24** between optical element **18** and the front sight **12**. The second focal length of optical element **18** is selected so that it is about equal to a distance **26** between optical element **18** and an expected position of a target **28**. By way of example, in one embodiment, the first focal length is selected to be about 83 cm (about 33 inches), whereas the second focal length is selected to be infinity (∞). Thus, sighting optics **10** according to the teachings provided herein will bring into substantially simultaneous focus (i.e., as virtual images for a user's eye **30**) both the front sight **12** and the target **28**. See FIG. **2**.

In one embodiment, optical element **18** may comprise a focusing element, such as a lens **32**, as best seen in FIGS. **3** and **4**. Lens **32** performs a diffractive focusing function and/or a refractive focusing function in order to bring into simultaneous focus images of objects located at about the first and second focal lengths. More specifically, in one embodiment, lens **32** may comprise a central region or area **34** surrounded by annular rings **36**. The central region or area **34** provides the refractive function, whereas the annular rings **36** provide the diffractive function. As will be explained in greater detail herein, the sizes, configurations, and arrangements of the central area **34** and rings **36** are configured to vary the diffraction efficiency of the lens **32** so that it can bring into simultaneous focus objects located at both the first focal length and the second focal length.

In addition to providing the simultaneous focusing function, the lens **32** may also be configured to divide or partition light unequally from the two different focal lengths. For example, a lens **32** according to the teachings provided herein may be constructed so that it biases or partitions more light to the first focal length relative to the second focal length. Accordingly, such a partitioned lens **32** will increase the brightness of images of objects located at the first focal length (e.g., the front sight **12**) relative to objects located at the second focal length (e.g., the target **28**). Alternatively, lens **32** may be constructed with an opposite bias or partition. That is, lens **32** may be constructed so that it biases or partitions more light to the second focal length relative to the first focal length, thereby increasing the brightness of the image of the target **28** relative to the front sight **12**.

Many other types and configurations of optical element **18** are possible, several of which are shown and described herein. For example, in another embodiment, an optical element **118** may comprise a diffractive element, such as a zone plate **132** illustrated in FIGS. **5** and **6**. However, unlike lens **32**, zone plate **132** performs purely diffractive (as opposed to refractive and diffractive) focusing functions in order to bring into simultaneous focus images of objects located at about the first and second focal lengths. Other embodiments of the optical element may comprise other configurations and/or may be used in conjunction with additional optical elements to provide the dual focus capability and other optical functions, such as corrections for vision irregularities in a user's eye or to provide image magnification, as will be described in greater detail below.

A significant advantage of the sighting optics according to the teachings of the present invention is that they can be used to bring into substantially simultaneous focus virtual images of objects located at two different positions on the object side **20** of optical element **18**. When used in a sighting application, e.g., as a rifle or a bow sight, the sighting optics according to

the teachings provided herein will allow a user to see, simultaneously, well-focused images of both the front sight and the target, thereby enhancing the ability of the user to acquire and hit the target. Another advantage of the sighting optics of the present invention is that they can be made very small, light, and robust, providing a size, weight, durability, and ruggedness similar to that of conventional "iron sights," but with aiming abilities more akin to those possible with conventional telescopic sights.

Still other advantages are associated with the ability to design the sighting optics so that they bias or partition the light unequally between objects located at the first and second focal lengths. For example, it may be advantageous in certain applications to provide sighting optics that are biased to the first focal length, thereby providing enhanced brightness of the front sight relative to the target. Conversely, it may be advantageous in other applications to provide sighting optics that provide enhanced brightness of the target relative to the front sight, for example, when the target stands at a significant distance.

Having briefly described certain embodiments and variations of sighting optics according to the teachings provided herein, as well as some of their more significant features and advantages, various embodiments and alternative configurations of the sighting optics will now be described in detail. However, before proceeding with the detailed description, it should be noted that while the sighting optics are shown and described herein as they could be used in conjunction with rifles of the type utilized in military and civilian applications, they may be utilized in a wide variety of other applications as well, as would become apparent to a person having ordinary skill in the art after having become familiar with the teachings provided herein. Consequently, the present invention should not be regarded as limited to the particular arrangements and applications shown and described herein.

Referring back now to FIG. **1**, sighting optics **10** according to one embodiment of the present invention may comprise a front sight **12** and a rear sight **14**. The front and rear sights **12** and **14** may be mounted in a spaced-apart relation on a suitable sighting platform, such as a gun barrel **16**. In the embodiment shown and described herein, the front sight **12** may comprise a configuration, such as a post, a bead, or a ring-shaped structure of the type commonly utilized in so-called "iron sights." The front sight **12** may be provided at or near the end **38** of gun barrel **16**, although other locations along the length of the barrel **16** are possible, as would become apparent to a person having ordinary skill in the art after having become familiar with the teachings provided herein.

Rear sight **14** may be mounted at a rearward location on gun barrel **16**, so that a user's eye **30** can conveniently sight through sighting optics **10** and see the virtual images produced by optical element **18**, as shown in FIGS. **1** and **2**. Alternatively, rear sight **14** could be mounted at other locations, such as the gun receiver, as would become apparent to a person having ordinary skill in the art after having become familiar with the teachings provided herein. In the embodiment shown and described herein, rear sight **14** may comprise a frame or housing **40** sized to receive optical element **18**. Alternatively, a housing **40** need not be used, in which case rear sight **14** and optical element **18** would be one and the same.

Frame or housing **40** may comprise any of a wide variety of structures, materials, and configurations depending on the intended application, the particular type of optical element **18** that is to be utilized, as well as on whether any other elements or devices (e.g., lenses, aperture rings, irises, etc.) are to be provided on, inside, or in conjunction with, housing **40**. Con-

sequently, the present invention should not be limited to a housing 40 having any particular type of structure or configuration. However, by way of example, in one embodiment, housing 40 may comprise a generally cylindrically shaped structure sized to receive the optical element 18 in the manner illustrated in FIG. 1.

Housing 40 also may be configured to be attached to gun barrel 16 such as, for example, by one or more mounts 42. Mounts 42 may be configured to allow housing 40 to be readily attached to and removed from gun barrel 16, although quick attachment and removal of the housing 40 are not required. In addition, mounts 42 may be configured to allow housing 40 to be adjusted or aimed to allow proper "sighting" of sighting optics 10. Housing 40 may be fabricated from any of a wide variety of materials, such as metals or plastics, suitable for the intended application. By way of example, in one embodiment, housing 40 is fabricated from aluminum.

As briefly mentioned above, sighting optics 10 need not be mounted to a gun barrel 16 and used in connection with a rifle, but could instead be used in any of a wide variety of applications and in conjunction with any of a wide variety of devices wherein the sighting optics 10 of the present invention could be used to advantage. For example, in another application, the front and rear sights (e.g., front sight 12 and rear sight 14) could be mounted to a bow or a crossbow and used in archery applications. In such an application, it may be necessary or desirable to mount the front and rear sights 12 and 14, respectively, on a separate sighting platform or structure that is mounted to the bow. Alternatively, since sighting optics 10 can be very small, light, and rugged, sighting optics 10 could be mounted on the bowstring and serve as a rear sight for a bow. Still other arrangements are possible, as would become apparent to a person having ordinary skill in the art after having become familiar with the teachings provided herein. Consequently, the present invention should not be regarded as limited to the particular applications and configurations shown and described herein.

Proceeding now with the description, one embodiment of optical element 18 is best seen in FIGS. 3 and 4 and may comprise a lens 32 capable of bringing into substantially simultaneous focus, as virtual images, images of objects located at two different positions, or focal lengths, on the object side 20 of lens 32. See also FIG. 1. In order for lens 32 to simultaneously form well-focused virtual images of objects located at two different focal lengths (i.e., first and second focal lengths), lens 32 is provided with refractive and diffractive focusing functions.

One way to achieve the refractive and diffractive focusing functions is to provide lens 32 with a central area 34 that is surrounded by a plurality of rings 36. Central area 34 may comprise a convex surface to provide the refractive focusing function, whereas the rings 36 provide the diffractive focusing function of lens 32.

In order to provide the dual focus capability described herein, i.e., in order for lens 32 to have the first and second focal lengths, a minimum number of rings 36 (typically at least three) needs to be provided. The diameters of the rings 36 will vary depending on the first focal length, the second focal length, and the degree of partitioning desired between the first and second focal lengths. Additionally, the design wavelength (i.e., the wavelength, for design purposes, that is most representative of the predominant illumination present in the environment where the lens 32 will be used) will have an effect on the ring 36 diameters and corresponding clear aperture 44 of lens 32.

Because lens 32 provides a diffractive focusing function, the front sight 12 and target 28 focal lengths may correspond

to different focusing "orders" of lens 32. For example, in one embodiment, the distance 24 (FIG. 1) between optical element 18 and front sight 12 (i.e., a first focal length) corresponds to a primary focusing order of lens 32. The distance 26 (FIG. 1) between optical element 18 and target 28 (i.e., a second focal length) corresponds to an infinite focusing order of lens 32. Stated another way, the virtual image of the front sight 12 is formed by the primary focusing order of lens 32, whereas the virtual image of the target 28 is formed by the infinite focusing order of lens 32.

The selections of the particular physical features (e.g., the central area 34 and rings 36) required to provide lens 32 with the desired optical properties (e.g., primary and infinite focusing orders, degree of partitioning between the first and second focal lengths, design wavelength, etc.) may be arrived at by using any of a wide variety of computer programs now known in the art or that may be developed in the future for determining physical lens features based on desired lens performance. By way of example, in one embodiment, the various physical features of lens 32 (e.g., numbers and diameters of the rings 36) presented in Table 1 were calculated by a computer program known as CODE V®, and currently available from Optical Research Associates, Pasadena, Calif., U.S.

Table 1 presents ring diameters required for two different first focal lengths (e.g., 60 cm and 83 cm) as well as for two different design wavelengths (e.g., 550 nm and 590 nm) for a lens 32 made from fused silica. The data in Table 1 were also determined for substantially equal partitioning between the first and second focal lengths, respectively. Because, in one embodiment, the second focal length is selected to be infinity (cc), often referred to as the zero order beam of lens 32, the physical lens parameters need not be varied to accomplish focusing at infinity. Depth of field is significant for human vision. Objects will appear to be in focus from infinity all the way down to distances on the order of twenty meters. That is, the effective range of focus for the infinite focal length extends out from about twenty meters. Such a focus capability will be sufficient for virtually all applications. However, if the second focal length is desired to be less than infinity (i.e., less than about twenty meters), then the physical parameters of lens 32 will need to take into account this desired target focal length. In particular, addition of small refractive correction to the light focused by the infinite focusing order diffractive capability will accommodate those cases where it is not. In any event, the ability to select the second focal length to be any desired distance will be within the level of a person having ordinary skill in the art after having become familiar with the teachings provided herein.

TABLE 1

Ring	f = 83 cm ($\lambda = 550$ nm)	f = 60 cm ($\lambda = 550$ nm)	f = 83 cm ($\lambda = 570$ nm)	f = 60 cm ($\lambda = 570$ nm)
	Diameter (mm)	Diameter (mm)	Diameter (mm)	Diameter (mm)
1	1.8510	1.5736	1.8844	1.6020
2	2.6610	2.2622	2.7090	2.3030
3	3.2766	2.7856	3.3356	2.8358
4	3.7936	3.2250	3.8620	3.2832
5	4.2480	3.6114	4.3246	3.6764
6	4.6584	3.9602	4.7424	4.0316

As can be seen from the data in Table 1, the overall clear aperture 44 for a lens 32 having the minimum number of three complete rings 36 will be about 3.3 mm for a first focal length (e.g., distance 24 (FIG. 1)) of about 83 cm, a second focal length (e.g., distance 26 (FIG. 1)) of infinity (∞), and a design wavelength λ of about 550 nm. It should also be noted that the

clear aperture **44** of lens **32** decreases as the first focal length decreases, but increases with increasing design wavelength λ .

It should be noted that while the lens **32** illustrated in FIGS. **3** and **4** resembles a Fresnel lens, it differs from a conventional Fresnel lens in several important respects. For example, conventional Fresnel lenses are not usually designed with dual focal lengths and are not typically designed to perform any diffractive focusing function. Indeed, if the clear aperture **44** of lens **32** fails to include a minimum number of rings **36**, the diffractive focusing function of the lens **32** will be minimized to the point where the lens **32** would behave as a conventional refractive lens, thereby failing to achieve the desired functionality.

In one embodiment, lens **32** is selected to have a first focal length of about 83 cm, a second focal length of infinity (∞), a design wavelength λ of about 550 nm, a back focal length of about 8 cm, and substantially equal partitioning between the first and second focal lengths. In addition, it was desired to provide lens **32** with six (6) rings **36** (instead of the minimum number of three (3) rings **36**), in order to increase overall image brightness. These requirements resulted in a lens **32** having a clear aperture **44** of about 5 mm and a thickness **46** of about 1 mm. The six (6) rings **36** were provided having the specified diameters set forth in Table 1 for the corresponding first focal length and design wavelength λ . The lens **32** comprised fused silica.

While the lens data presented in Table 1 will result in a lens **32** having substantially equal partitioning between the first and second focal lengths, other embodiments may be configured to provide unequal partitioning between the first and second focal lengths. For example, in another embodiment, lens **32** may partition about 60% of the light to the first focal length and about 40% to the second focal length. In still yet another alternative embodiment, lens **32** may partition about 40% of the light to the first focal length and about 60% to the second focal length. Lenses **32** having the characteristics described herein are available from and may be manufactured "to order" by Tessera North America, Inc., Charlotte, N.C., U.S. Alternatively, lenses **32** having such unequal partitioning may be fabricated in accordance with the teachings provided in U.S. Pat. No. 5,017,000, entitled "Multifocals Using Phase Shifting" which is hereby incorporated herein by reference for all that it discloses.

As already mentioned, rear sight **14** may be provided with additional elements and/or devices to enhance the performance of the sighting optics **10**, as may be desired for a particular application. For example, in the embodiment illustrated in FIG. **1**, the rear sight **14** may be provided with a supplemental lens **48** that may be located between the optical element **18** and the user's eye **30**. Supplemental lens **48** may be used to provide any of a wide range of functions, such as, for example, spherical power correction, cylindrical power correction, or a combination of both, in order to correct for deficiencies in the user's eye **30**. The provision of such a supplemental lens **48** may thereby allow a user to use the sighting optics **10** without the need for glasses. In another embodiment, the supplemental lens **48** may provide magnification, allowing the user's eye **30** to perceive enlarged virtual images of the front sight **12** and target **28**.

As mentioned above, sighting optics **10** may comprise a number of variations and modifications, many of which are shown and described herein. For example, and with reference now primarily to FIGS. **5** and **6**, a second embodiment of the optical element **118** may comprise a diffractive element, such as a zone plate **132**. Unlike lens **32** for the first embodiment of optical element **18** (FIG. **1**), the zone plate **132** performs

purely diffractive focusing functions in order to bring into simultaneous focus images of objects located at or near the first and second focal lengths.

More specifically, in the embodiment illustrated in FIGS. **5** and **6**, zone plate **132** may comprise an optically transparent substrate **150** having a plurality of opaque rings **136** provided thereon. In one embodiment, the rings **136** are arranged so that zone plate **132** comprises a substantially open (i.e., transparent) central region **134**. To achieve constructive interference and focusing, every other zone should be blocked, but only those with odd values of "m" within the formula $R_m \approx (f\lambda m/n)^{1/2}$, where "R_m" is the radii of the boundaries between the zones, "f" is the focal length, "λ" is the wavelength, and "n" is the refractive index. Blocking zones with even values of "m" would result in only destructive interference. The central region **134** could be blocked or made opaque and still achieve focusing, but this would produce a further loss of light with no known benefit.

The first focal length of zone plate **132** may correspond to the first focusing order of the zone plate **132**, whereas the second focal length of zone plate **132** may correspond to the zeroth focusing order of the zone plate **132**. As was the case for the lens **32** of the first embodiment, the number, sizing, and spacing of the rings **136** of zone plate **132** may be determined based on the various optical parameters desired for zone plate **132**. The various optical parameters may include the first focal length, the second focal length, the design wavelength, and the desired degree of partitioning between the respective first and second focal lengths. Any of a wide variety of computer programs now known in the art or that may be developed in the future may be used to select the number, sizing, and spacing of the rings **136** of zone plate **132** based on the specified optical parameters. However, because a person having ordinary skill in the art would be capable of designing a zone plate **132** having such optical parameters, after having become familiar with the teachings provided herein, particular examples for designing such zone plates **132** will not be described in further detail herein.

A third embodiment of an optical element **218** is illustrated in FIGS. **7** and **8**. The optical element **218** may be advantageous in cases requiring long first focal lengths and small clear apertures. More specifically, the optical element **218** of the third embodiment may comprise a transparent member or "lens" **232** comprising a curved portion **254** that is partitioned by a series of concentric rings **252**. The concentric rings **252** directly transmit light to pass the target image unaltered, whereas the curved portions **254** between adjacent concentric rings **252** produce the lens (i.e., refractive focusing) function, bringing the front sight **12** into focus. In this embodiment, then, the first focal length (for the front sight **12**) is controlled by the curvature of the curved portion **254**, whereas the second focal length (i.e., for the target **28**) is controlled by the concentric rings **252**. The transparent member **232** may be manufactured by etching a glass blank to produce the desired curved portion **254** while leaving the concentric rings **252** unetched. Alternatively, such a lens **232** may be obtained from Tessera North America, Inc.

A fourth embodiment of an optical element **318** is illustrated in FIG. **9**. The optical element **318** is similar to the optical element **18** of the first embodiment and comprises a lens **332** having a central area **334** surrounded by a minimum of three rings **336**. However, unlike the first embodiment, each of the three rings **336**, as well as the central area **334**, is provided with a plurality of steps **356**. Steps **356** are sized and spaced so as to create annular zones approximating the angled annular surfaces as are represented by rings **336** to produce constructive interference at the design wavelength. Steps **356**

may be formed with the necessary precision using a multi-mask photo etching process and may be obtained from Tessera North America, Inc.

A fifth embodiment of an optical element **418** is illustrated in FIG. **10**. Optical element **418** may be provided with an integral supplemental “lens” formed by a curved image side surface **448**. The integral lens formed by curved image side surface **448** may be used to provide any of a wide variety of optical functions. For example, in one application, curved image side surface **448** may be used to replace the separate lens **48** illustrated in FIG. **1**. Stated another way, curved image side surface **448** may be configured to supply spherical power correction, cylindrical power correction, or a combination of both, in order to correct for vision deficiencies of the user’s eye **30**. Curved image side surface **448** may also be used to provide magnification to the virtual images of the front sight **12** and target **28** formed by optical element **18**.

Having herein set forth embodiments of the present invention, it is anticipated that suitable modifications can be made thereto which will nonetheless remain within the scope of the invention. The invention shall therefore only be construed in accordance with the following appended claims.

The invention claimed is:

1. Sighting optics, comprising:
 - a front sight;
 - an optical element spaced from the front sight, wherein the optical element is positioned between the front sight and an intended position for a user’s eye, and the optical element is configured to substantially simultaneously focus the front sight and a target to enable the user’s eye to perceive substantially focused images of the front sight and the target simultaneously; and
 - wherein the optical element comprises a transparent member comprising a plurality of transparent rings surrounding a central unoccluded area of the optical element, and wherein at least one portion of the transparent member extending radially between at least two adjacent rings of the plurality of rings comprises an unoccluded area.
2. The sighting optics of claim **1**, wherein the optical element comprises a refractive element.
3. The sighting optics of claim **2**, wherein the refractive element comprises the central unoccluded area of the optical element surrounded by the plurality of rings, wherein the

central unoccluded area of the optical element provides a refractive focusing function and the plurality of rings of the optical element provides a diffractive focusing function.

4. The sighting optics of claim **3**, wherein the front sight is substantially focused by a primary focusing order of the optical element and wherein the target is substantially focused by an infinite focusing order of the optical element.

5. The sighting optics of claim **1**, wherein the optical element comprises a diffractive element.

6. The sighting optics of claim **1**, wherein the optical element comprises a convex surface on a surface of the optical element opposite the intended position for a user’s eye.

7. The sighting optics of claim **1**, wherein each ring of the plurality of rings and the central area comprises a plurality of steps sized and spaced to produce constructive interference at a design wavelength to provide a focusing function.

8. The sighting optics of claim **1**, wherein the optical element comprises an object side and an image side, the object side of the optical element comprising a curved central area surrounded by the plurality of rings, and the image side of the optical element comprising a curved surface.

9. The sighting optics of claim **8**, wherein the curved surface provides at least one of spherical power correction and cylindrical power correction.

10. The sighting optics of claim **8**, wherein the curved surface magnifies the front sight and the target.

11. Sighting optics, comprising:

a front sight; and

an optical element spaced from the front sight, the optical element comprising a transparent member comprising a plurality of concentric transparent rings protruding from the transparent member and surrounding a central unoccluded area of the optical element positioned in a central opening surrounded by the plurality of concentric transparent rings, wherein the optical element is positioned between the front sight and an intended position for a user’s eye, and the optical element is configured to substantially simultaneously focus the front sight and a target to enable the user’s eye to perceive substantially focused images of the front sight and the target simultaneously.

* * * * *