



US009281044B2

(12) **United States Patent**
Ramaswamy et al.

(10) **Patent No.:** **US 9,281,044 B2**
(45) **Date of Patent:** **Mar. 8, 2016**

(54) **APPARATUSES HAVING A FERROELECTRIC FIELD-EFFECT TRANSISTOR MEMORY ARRAY AND RELATED METHOD**

6,532,165 B1 3/2003 Katori
6,819,581 B2 11/2004 Ito
7,233,024 B2 6/2007 Scheuerlein et al.
7,433,233 B2 10/2008 Chen et al.
8,054,673 B2 11/2011 Wang et al.
8,148,759 B2 4/2012 Wilson et al.
8,169,827 B2 5/2012 Guzzi et al.
8,304,823 B2 11/2012 Boescke

(71) Applicant: **Micron Technology, Inc.**, Boise, ID (US)

(Continued)

(72) Inventors: **D. V. Nirmal Ramaswamy**, Boise, ID (US); **Adam D. Johnson**, Boise, ID (US)

FOREIGN PATENT DOCUMENTS

(73) Assignee: **MICRON TECHNOLOGY, INC.**, Boise, ID (US)

JP 2000-340760 A 12/2000

(*) Notice: Subject to any disclaimer, the term of this patent is extended or adjusted under 35 U.S.C. 154(b) by 224 days.

OTHER PUBLICATIONS

(21) Appl. No.: **13/897,037**

International Search Report, ISA/KR, International Application No. PCT/US2014/038110, Oct. 20, 2014, three (3) pages.

(Continued)

(22) Filed: **May 17, 2013**

Primary Examiner — Han Yang

(74) Attorney, Agent, or Firm — TraskBritt

(65) **Prior Publication Data**

(57) **ABSTRACT**

US 2014/0340952 A1 Nov. 20, 2014

An apparatus comprises field-effect transistor (FET) structures stacked horizontally and vertically in a three-dimensional memory array architecture, gates extending vertically and spaced horizontally between the plurality of FET structures, and a ferroelectric material separating the FET structures and the gates. Individual ferroelectric FETs (FeFETs) are formed at intersections of the FET structures, the gates, and the ferroelectric material. Another apparatus comprises a plurality of bit lines and word lines. Each bit line has at least two sides that are coupled with a ferroelectric material such that each bit line is shared by neighboring gates to form a plurality of FeFETs. A method of operating a memory array comprises applying a combination of voltages to a plurality of word lines and digit lines for a desired operation for a plurality of FeFET memory cells, at least one digit line having plurality of FeFET memory cells accessible by neighboring gates.

(51) **Int. Cl.**
G11C 11/22 (2006.01)

(52) **U.S. Cl.**
CPC **G11C 11/221** (2013.01); **G11C 11/22** (2013.01); **G11C 11/2255** (2013.01); **G11C 11/2257** (2013.01)

(58) **Field of Classification Search**
CPC G11C 11/22; G11C 11/2255; G11C 11/2257; G11C 11/223
USPC 365/145, 174, 175, 149
See application file for complete search history.

(56) **References Cited**

U.S. PATENT DOCUMENTS

6,370,056 B1 4/2002 Chen et al.
6,477,078 B2 11/2002 Hönigschmid et al.

33 Claims, 11 Drawing Sheets

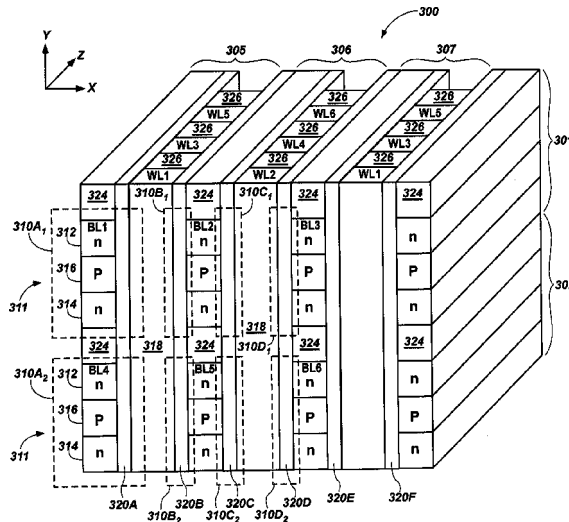

(56)

References Cited

U.S. PATENT DOCUMENTS

8,394,683	B2	3/2013	Ramaswamy et al.	
2007/0236979	A1	10/2007	Takashima	
2010/0072552	A1	3/2010	Sunami et al.	
2010/0073988	A1*	3/2010	Takahashi et al.	365/145
2011/0188288	A1	8/2011	Minami	
2012/0195094	A1*	8/2012	Greco	G11C 11/22 365/145
2012/0275220	A1*	11/2012	Liu et al.	365/185.03
2013/0043455	A1	2/2013	Bateman	
2013/0051150	A1*	2/2013	Roizin	H01L 29/7926 365/185.18

OTHER PUBLICATIONS

Written Opinion of the International Searching Authority, ISA/KR, International Application No. PCT/US2014/038110, Oct. 20, 2014, six (6) pages.

Ishiwara et al., Proposal of a Single-Transistor-Cell-Type Ferroelectric Memory Using an SOI Structure and Experimental Study

on the Interference Problem in the Write Operation, Jpn. J. Appl. Phys., vol. 36, Part 1, No. 3B, Mar. 1997, pp. 1655-1658.

Ohshima, Jeff, State-of-the-Art Flash Memory Technology, Looking into the Future, GSA/Sematech Memory Conference, Apr. 16, 2012, 18 pages.

Sakai et al., Highly Scalable Fe(Ferroelectric)-NAND Cell with MFIS (Metal-Ferroelectric-Insulator-Semiconductor) Structure for Sub-10nm Tera-Bit Capacity NAND Flash Memories, Non-Volatile Semiconductor Memory Workshop, 2008 and 2008 International Conference on Memory Technology and Design, May 18-22, 2008, pp. 103-105.

Von Bieren et al., Presentation Summary, FeFET—The Memory Technology of Tomorrow? Oct. 17, 2006, 5 pages.

Yurchuk et al., HFO₂-Based Ferroelectric Field-Effect Transistors with 260 nm Channel Length and Long Data Retention, Memory Workshop (IMW), 2012 4th IEEE International, May 20-23, 2012, 4 pages.

Office Action for Taiwanese Patent Application No. 103117392, issued Sep. 11, 2015, pages.

* cited by examiner

APPARATUSES HAVING A FERROELECTRIC FIELD-EFFECT TRANSISTOR MEMORY ARRAY AND RELATED METHOD

FIELD

Embodiments of the present disclosure relate to ferroelectric field-effect transistor (FeFET) structures. In particular, embodiments of the present disclosure relate to memory arrays employing FeFETs.

BACKGROUND

Ferroelectric field-effect transistors have been considered for use in memory arrays in the form of non-volatile random access memory. For example, FIGS. 1A and 1B are schematic diagrams of a conventional memory array 100 including a plurality of FeFETs 110. In particular, the portion of the memory array 100 in FIG. 1A is the cross-section taken along line 1A of the top view shown in FIG. 1B. Each FeFET 110 includes a source region 112, a drain region 114, and a body region 116 (collectively referred to herein as an “FET structure”) formed over an insulating substrate 130. Each FeFET 110 may include a gate 118 separated from the FET structure by a ferroelectric material 120. In other words, at a very general level, a FeFET may have a similar structure to a conventional FET, with the gate oxide being replaced by the ferroelectric material 120. Each FeFET 110 may comprise a memory cell for the memory array 100.

The memory array 100 includes the plurality of two-dimensional (planar) arrangement of FeFETs 110 over the insulating substrate 130. Each FeFET 110 may comprise a memory cell for the memory array 100 to store a state to be interpreted as data. The state of the FeFET 110 may be based on the polarization of the ferroelectric material 120 that may be switched in the presence of an external field. For example, the ferroelectric material 120 may exhibit a positive polarization (which may be interpreted as a “1”) or a negative polarization (which may be interpreted as a “0”) for an individual FeFET 110. In operation, the FeFET 110 may receive a combination of voltages to contacts coupled to the gate 118, the source region 112, and the drain region 114 in order to write to, erase, or read the state of the FeFET 110.

During a read operation, current 102 may flow through the FeFET 110 from the source region 112 to the drain region 114 of the selected FeFET 110. The conventional memory array 100 may have source contacts and drain contacts (not shown) that are on the same side of the memory array 100. As a result, the current 102 may flow from a first end 150 of the memory array 100 through the FeFET 110 and then return to the same first end 150 of the memory array 100. As a result, the current path may have a different length depending on the position of the FeFET 110 in the memory array 100. For example, the current 102 may have a path that is shorter for a FeFET 110 that is proximate the first end 150 and longer for a FeFET 110 that is proximate a second end 152 of the memory array 100. As a result, the series resistance along the current path may not be uniform when accessing one FeFET 110 in comparison to the accessing another FeFET 110 in the memory array 100. In addition, the conventional memory array 100 configured in a two-dimensional architecture may have feature sizes that are undesirably large, and which may not enable a cell density that is practical for use.

BRIEF DESCRIPTION OF THE DRAWINGS

FIGS. 1A and 1B are schematic diagrams of a conventional memory array including a plurality of FeFETs.

FIG. 2 is a schematic diagram of a FeFET according to an embodiment of the present disclosure.

FIG. 3A is a perspective view of a schematic diagram of a memory array according to an embodiment of the present disclosure.

FIG. 3B is a top view of a portion of the memory array of FIG. 3A.

FIG. 4A is a perspective view of a schematic diagram of a memory array according to another embodiment of the present disclosure.

FIG. 4B is a top view of a portion of the memory array of FIG. 4A.

FIGS. 5 through 7 are top views of a schematic diagram of memory arrays showing various contacting schemes for the word line contacts.

FIG. 8 is a perspective view of a memory array showing a contacting scheme for a memory array that includes a plurality of word lines.

FIG. 9 is a perspective view of a portion of a memory array.

FIG. 10 is a schematic circuit diagram of a portion of a memory array according to an embodiment of the present disclosure.

FIG. 11 is a perspective view of a schematic diagram of a portion of a memory array according to another embodiment of the present disclosure.

FIG. 12 is a simplified block diagram of an electrical system including a vertical memory cell.

DETAILED DESCRIPTION

In the following detailed description, reference is made to the accompanying drawings that form a part hereof, and in which is shown by way of illustration specific embodiments of the present disclosure. These embodiments are described with specific details to clearly describe the embodiments of the present disclosure. However, the description and the specific examples, while indicating examples of embodiments of the present disclosure, are given by way of illustration only and not by way of limitation. Other embodiments may be utilized and changes may be made without departing from the scope of the disclosure. Various substitutions, modifications, additions, rearrangements, or combinations thereof may be made and will become apparent to those of ordinary skill in the art. In addition, features from one embodiment may be combined with features of another embodiment while still being encompassed within the scope of the disclosure as contemplated by the inventor.

It should be understood that any reference to an element herein using a designation such as “first,” “second,” and so forth does not limit the quantity or order of those elements, unless such limitation is explicitly stated. Rather, these designations may be used herein as a convenient method of distinguishing between two or more elements or instances of an element. Thus, a reference to first and second elements does not mean that only two elements may be employed or that the first element must precede the second element in some manner. In addition, unless stated otherwise, a set of elements may comprise one or more elements.

It should also be understood that discussion herein regarding a specific number of memory cells should not be interpreted to limit the number of memory cells that may be present in a memory array or any portion thereof. Rather, specific numbers may be referred to when discussing the depicted embodiments. Embodiments of the present disclosure, however, may include any number of memory cells, which may approximately equal the number of FeFETs formed by the 3D memory array architecture. In some

embodiments, at least some of the memory cells may be reserved for use as replacement memory cells to replace other memory cells within the memory array, such as if memory cells are determined to be defective in some way. Thus, for some embodiments, the overall capacity of the memory array may be less than the total number of memory cells. In addition, the memory array may be used to replace another memory array.

The materials and structures described herein may be formed by any suitable technique including, but not limited to, spin coating, blanket coating, chemical vapor deposition (CVD), atomic layer deposition (ALD), plasma enhanced ALD, or physical vapor deposition (PVD), unless otherwise specified. Depending on the specific material to be formed, the technique for depositing or growing the material may be selected by a person of ordinary skill in the art. Structural elements may be formed in the locations and configurations described herein using conventional semiconductor fabrication techniques. While the materials described and illustrated herein may be formed as layers, the materials are not limited thereto and may be formed in other three-dimensional configurations.

As used herein, the term “substantially” in reference to a given parameter, property, or condition means and includes to a degree that one of ordinary skill in the art would understand that the given parameter, property, or condition is met with a small degree of variance, such as within acceptable manufacturing tolerances. By way of example, depending on the particular parameter, property, or condition that is substantially met, the parameter, property, or condition may be at least 90% met, at least 95% met, or even at least 99% met.

Embodiments of the present disclosure include apparatuses comprising FeFET memory arrays. For example, a plurality of FET structures may be stacked horizontally and vertically in a three-dimensional memory array architecture, a plurality of gates extending vertically and spaced horizontally between the plurality of FET structures, and a ferroelectric material separating the plurality of FET structures and the plurality of gates. Individual ferroelectric FETs (FeFETs) may be formed at intersections of the plurality of FET structures, the plurality of gates, and the ferroelectric material. Some embodiments may include a first vertical FeFET stack including a first plurality gates that are separated from a first FET structure by a first ferroelectric material, and a second vertical FeFET stack including a second plurality gates that are separated from a second FET structure by a second ferroelectric material. The first vertical FeFET stack and the second FeFET stack may be stacked horizontally and separated by a dielectric material. Some embodiments may include a three-dimensional memory array having a plurality of FeFET memory cells formed at intersections of ferroelectric material coupled with a plurality of bit lines and a plurality of word lines. The plurality of FeFET memory cells may be formed along vertical strings of the three-dimensional memory array, wherein the vertical strings couple with memory cell gates coupled with the plurality of word lines. The vertical strings may each include a vertical channel surrounded by the ferroelectric material.

FIG. 2 is schematic diagram of a FeFET 200 according to an embodiment of the present disclosure. The FeFET 200 may be a memory cell of a larger memory array (see, e.g., FIGS. 3A through 10). The FeFET 200 includes a drain region 212, source region 214, and body region 216 coupled to a gate 218 that is separated by a ferroelectric material 220. The drain region 212 may be coupled to a drain contact 222, the source region 214 may be coupled to a source contact 224, and the gate 218 may be coupled to a gate contact 228. The

source region 214 and the body region 216 may be tied together to the same source contact 224, which may reduce the number of contacts over conventional FeFET memory cells.

The ferroelectric material 220 is a dielectric material (e.g., hafnium oxide (HfOx)) that may exhibit polarization (e.g., a displacement of oppositely charged ions and create a dipole moment) that is switchable by an external field. In addition, the remnant polarization of the ferroelectric material 220 may not vanish after turning off the external field. As a result, the polarization of the ferroelectric material 220 may be interpreted as the state (e.g., “1” or “0”) of the memory cell. The polarization may be determined by measuring the resistivity of the FeFET 200, which resistivity is dependent on the polarization state of the ferroelectric material 220. In other words, the state of the polarization may effectively show up as a threshold voltage (V_t) shift in the FeFET 200 based on the polarization of the ferroelectric material 220, which may be sensed by detecting the threshold voltage of the FeFET 200 under a low bias. Because the remnant polarization of the ferroelectric material 220 may remain (i.e., be non-volatile), the FeFET 200 may not need to be refreshed as with other RAM technologies that employ cell capacitors as a storage element.

The drain region 212, the source region 214, and the body region 216 may be formed from doped semi-conductive material (e.g., n-type semi-conductive material, p-type semi-conductive material). Although the drain region 212, the source region 214, and the body region 216 are shown in FIG. 2 (and other figures herein) as an npn structure, some embodiments may include a pnp structure.

In operation, the FeFET 200 may be read, written to, erased, etc., according to the bias voltage applied to the drain contact 222, source contact 224, and the gate contact 228. In particular, the polarity of the ferroelectric material 220 may be changed (e.g., write, erase) or sensed (e.g., read) depending on the desired operation. For example, a write operation may include applying a positive gate-source voltage (V_{GS}) (e.g., $V_G=3V$, $V_S=0V$, $V_D=0V$) that has a larger amplitude than the coercive field of the ferroelectric material 220 to cause a first polarization to be present within the adjacent ferroelectric material 220. An erase operation may include applying a negative gate-source voltage ($-V_{GS}$) (e.g., $V_G=0V$, $V_S=3V$, $V_D=3V$) that has a larger amplitude than the coercive field of the ferroelectric material 220 to cause a second polarization to be present within the adjacent ferroelectric material 220. Although termed “erase,” the erase operation may simply be considered another write operation that writes the opposite state to the FeFET 200. Either polarization (i.e., positive or negative) may be interpreted as either a “1” or a “0,” as long as the two polarizations are interpreted differently from each other. A read operation may include applying a gate-source voltage (V_{GS}) (e.g., $V_G=1.5V$, $V_S=1V$, $V_D=1V$) that does not have a larger amplitude than the coercive field of the ferroelectric material 220.

Because of the dependence of the source-drain resistivity (i.e., the channel resistivity) on the polarization state of the ferroelectric material 220, the source-drain resistivity may be measured to determine the state of the FeFET 200. For example, if the electrons in the body region 216 are depleted (e.g., after $-V_{GS}$ has been applied causing a positive polarization of the ferroelectric material 220), the resistivity between the source region 214 and the drain region 212 is increased. If the electrons in the body region 216 results in an accumulation of electrons in the channel (e.g., V_{GS} is applied causing a negative polarization in the ferroelectric material 220), the resistivity between the source region 214 and the

5

drain region **212** is decreased. A read operation may include sensing the current received by the source contact **224** and determining the resistivity in response thereto.

The above operations are based on a $V/3$ selection scheme, by which a memory cell is selected (written to) if the $V_{GS} = \pm V$, and the memory cell is not selected if $V_{GS} = \pm V/3$ or $0V$. In the above example, $V=3$, such that $1=V/3$. Other sensing schemes (e.g., $V/2$ selection scheme) may also be employed as may be known by those of ordinary skill in the art.

Additional embodiments of the present disclosure include memory arrays that include a plurality of FeFETs **200**. When employed in a memory array, the drain region **212** may be coupled to a bit line (coupled to the drain regions for a plurality of FeFETs), and the gate **218** may be coupled to a word line (coupled to the gates for a plurality of FeFETs). The appropriate bit line and word line may be selected to access a desired memory cell. At times, for convenience, the drain region **212** may be referred to as the bit line (because it is coupled to the bit line contacts) and the gates **218** may be referred to as the word line (because it is coupled to the word line contacts).

The memory arrays have a three-dimensional (3D) architecture, which may result in a relatively high density 3D FeFET memory array that has random access. For example, in some embodiments, the memory array may include a $2F^2/n$ cell, where “F” is the minimum device feature size and “n” is the number of decks (described below). As a result, the memory array may achieve relatively higher cell density, lower power, and better cycling compared with other types of conventional memory arrays, while maintaining random access.

FIG. 3A is a perspective view of a schematic diagram of a memory array **300** according to an embodiment of the present disclosure. The x-axis, y-axis, and z-axis are provided in FIG. 3A to assist with the description to provide a point of reference and direction for certain features relative to each other. These axes are defined according to the orientation shown in FIG. 3A, which is not to be interpreted as requiring any particular orientation of the memory array **300** when fabricated or put into use. When oriented as shown, the direction along the x-axis will also be referred to as “horizontal,” and the direction along the y-axis will be referred to as “vertical.”

The memory array **300** includes a plurality of memory cells configured in a three-dimensional (3D) structure, which may roughly resemble a cube (e.g., 3D square) or cuboid (e.g., 3D rectangle) shape. Each memory cell may be configured as a FeFET. Therefore, at times, the terms “memory cell” and “FeFET” may be used interchangeably. As an example of one such memory cell, a FeFET **310A₁** includes a drain region **312**, a source region **314**, and a body region **316** coupled to a gate **318** that is separated by a ferroelectric material **320A**. The drain region **312**, the source region **314**, and the body region **316** may collectively be referred herein to as an FET structure **311**. Although each feature of each memory cell is not expressly labeled herein, each of the FeFETs **310A_{1,2}**, **310B_{1,2}**, **310C_{1,2}**, **310D_{1,2}** may be configured similarly. In addition, it is recognized that only some of the FeFETs (e.g., FeFETs **310A_{1,2}**, **310E_{3,1,2}**, **310C_{1,2}**, **310D_{1,2}**) of the memory array **300** are labeled in FIG. 3A, for convenience. Additional memory cells may be present at other locations where other FET structures **311**, gates **318**, and ferroelectric material **320A**, **320B**, **320C**, **320D**, **320E**, **320F** form FeFETs. The FET structures **311** may be configured as npn structures (as shown in FIG. 3A); however, some embodiments of the present disclosure may include FET structures **311** that are configured as pnp structures (not shown).

6

When oriented as shown in FIG. 3A, a plurality of FET structures **311** may be stacked vertically, with each FET structure **311** being separated by a dielectric material **324**. For example, the FET structure **311** of the first FeFET **310A₁** may be vertically stacked on the FET structure **311** of the second FeFET **310A₂**, and separated by the dielectric material **324**. The FeFETs (e.g., FeFET **310A₁**, FeFET **310A₂**) stacked in the same vertical FeFET stack (e.g., vertical FeFET stack **305**) may share a common gate **318**. In other words, an individual gate **318** may extend in the y-direction such that the individual gate **318** may be shared by different FET structures **311**. The corresponding ferroelectric material (e.g., ferroelectric material **320A**) may also be shared by FeFETs (e.g., FeFET **310A₁**, FeFET **310A₂**) of the same vertical FeFET stack (e.g., vertical FeFET stack **305**). The gate **318** and the ferroelectric material (e.g., ferroelectric material **320A**) may be offset (in the x-direction) to a side of the FET structure **311**. Thus, a FeFET stack **305**, **306**, **307** includes the FETs in a single y-z plane.

An individual FET structure **311** may extend in the z-direction such that the individual FET structure **311** may be associated with a plurality of different gates **318**. The ferroelectric material (e.g., ferroelectric material **320A**) may separate each of the different gates **318** and the FET structure **311**. As a result, individual memory cells may be formed along the individual FET structure **311** at each intersection where a different gate **318** is located. The different gates **318** may be parallel in the y-direction, and separated from each other in the z-direction by a dielectric material **326**. The number of individual FeFETs in a vertical FET stack (e.g., vertical FeFET stack **305**) may depend on the number of discrete gates **318** that are present in the z-direction as well as the number of FET structures **311**. For example, the vertical FeFET stack **305** shown in FIG. 3A includes three discrete gates **318** and two FET structures **311**. As a result, the vertical FeFET stack **305** may include six memory cells along the ferroelectric material **320A**.

In forming the 3D memory array architecture, vertical FeFET stacks **305**, **306**, **307** may be further stacked horizontally to form additional FeFETs (e.g., FeFETs **310B_{1,2}**, **310C_{1,2}**, **310D_{1,2}**). Each vertical FeFET stack may be separated from its respective neighboring vertical FeFET stacks by a ferroelectric material. For example, the first vertical FeFET stack **305** and the second vertical FeFET stack **306** may be separated by the ferroelectric material **320B**. Similarly, the second vertical FeFET stack **306** and the third vertical FeFET stack **307** may be separated by the ferroelectric material **320D**.

The vertical FeFET stacks **306**, **307** shown in FIG. 3A may each include six memory cells along the ferroelectric material **320C**, **320E**, respectively. Because the material separating neighboring vertical FeFET stacks **305**, **306**, **307** may be a ferroelectric material (e.g., ferroelectric material **320B**, **320D**), additional memory cells may be formed at the intersections between neighboring vertical FeFET stacks **305**, **306**, **307**. For example, FeFETs **310B_{1,2}** may be formed by the FET structures **311** of the second vertical FeFET stack **306**, the second ferroelectric material **320B**, and the gate **318** of the first vertical FeFET stack **305**. Similarly, FeFETs **310D_{1,2}** may be formed by the FET structures **311** of the third vertical FeFET stack **307**, the third ferroelectric material **320C**, and the gate **318** of the second vertical FeFET stack **306**. As a result, memory cells may be formed on each side of the gate **318**, because each gate **318** may have ferroelectric material coupled to the FET structures **311** on each side of the gate **318**.

Individual memory cells may be selected for an operation (e.g., read, write, erase, etc.) by applying an appropriate combination of voltages to the gate **318**, drain region **312** and source region **314**. Each gate **318** may also be considered an “access line” (e.g., word line) that is used to apply a common voltage to the gate **318** of the FeFETs (e.g., FeFET **310A₁**, FeFET **310A₂**) of the same row. Likewise, the drain region **312** may be considered an “access line” (e.g., bit line) that is used to apply a common voltage to the drain regions **312** of the same column. The terms “rows” and “columns” are not intended to require a particular orientation, but are merely used as a convenient way of distinguishing the difference between an access line for the drain region **312** and the access line for the gates **318**. For convenience, the terms “word line” (WL) and “bit line” (BL) will be used. The term “digit line” is sometimes used in the art for a bit line. Rows and columns are logical configurations and do not necessarily mean physical rows and columns. In the context of a 3D memory array, rows and columns may include memory cells that may be in different planes according to the word line and bit line contacting scheme.

As used herein, the term “deck” refers to a plurality of FeFETs stacked in the x-z plane. In other words, FeFETs of the same deck **301**, **302** may have FET structures **311** of different vertical FeFET stacks **305**, **306**, **307**, but that are parallel to each other along the same x-axis. For example, the first deck **301** includes FeFETs **310A₁**, **310B₁**, **310C₁**, **310D₁**, and the second deck **302** includes FeFETs **310A₂**, **310B₂**, **310C₂**, **310D₂**. Embodiments of the present disclosure may include any number of decks.

The neighboring gates **318** that are parallel along the same x-axis may not be part of the same word line. In other words, neighboring gates **318** that are parallel along the same x-axis do not receive the same voltage as each other during operation. For example, the gates **318** for a first group of gates **318** parallel along the same x-axis (within the same x-y plane) are part of word lines WL1, WL2, WL1, respectively. As a result, in some embodiments, the word lines (e.g., WL1, WL2) may alternate repeatedly moving along the memory array **300** in the x-direction. Similarly, moving back one level in the z-direction to a second x-y plane, the gates **318** of a second group of gates **318** may be part of word lines WL3, WL4, WL3, respectively. In addition, the gates **318** of a third group of gates **318** may be part of word lines WL5, WL6, WL5, respectively. In some embodiments, the word lines that are parallel each other along the same x-axis may have more than two word lines (e.g., WL1, WL2, WL3, etc.) that may or may not repeat, or that may have no particular repeatable pattern.

The memory array **300** of FIG. 3A is a simplified schematic diagram, and it should be recognized that additional elements may be coupled therewith to facilitate operation thereof. For example, contact elements may be coupled with the memory array **300** for applying voltages to the various elements (e.g., word lines, bit lines, etc.) of the memory array **300** to perform operations (e.g., read, write, erase, etc.) thereon. The memory array **300** may also include a control unit (not shown) that is coupled with the gate **318**, the drain region **312** and the source region **314**. Such a control unit may include at least one of string driver circuitry, pass gates, circuitry for selecting gates, circuitry for selecting conductive lines (e.g., bit lines, word lines), circuitry for amplifying signals, and circuitry for sensing signals.

In operation, the memory cells may be written to, erased, or read from in a manner similar to that discussed above with respect to FIG. 2. In some embodiments, a method of operating a FeFET memory array may comprise applying a combination of voltages to a plurality of word lines and digit lines

for a desired operation for a plurality of FeFET memory cells of a three-dimensional FeFET memory array, at least one digit line having plurality of FeFET memory cells accessible by neighboring gates. In particular, an appropriate combination of voltages may be applied to the contacts (not shown) such that the word lines and bit lines select the appropriate memory cell for the desired operation. For example, the FeFET **310A₁** may be selected by applying the appropriate voltages to the word line WL1 and the bit line BL1 for the desired operation according to the selection scheme (e.g., V/3, V/2, etc.) that is used. While the FeFET **310A₁** is selected, the other FeFETs **310A₂**, **310B_{1,2}**, **310C_{1,2}**, **310D_{1,2}** may not be selected according to the selection scheme that is used.

FIG. 3B is a top view of a portion of the memory array **300** of FIG. 3A. As with FIG. 3A, reference axes (in this case, the x-axis and z-axis) are provided to assist with the description to provide a point of reference and direction for certain features relative to each other. In particular, FIG. 3B shows the FeFETs **310A₁**-**310H₁** as an exemplary cross-section of the memory array **300** across the first deck **301**. However, it should be recognized that any number of FeFETs may exist in the y-direction (i.e., according to the number of decks **301**, **302**). As shown in FIG. 3A, there are two decks **301**, **302**. However, the memory array **300** may include any number of decks.

As discussed above, the neighboring gates **318** that are parallel along the same x-axis may not be part of the same word line. In other words, each FET structure **311** may be coupled to gates **318** of different word lines on the opposing sides of the FET structure **311** (in contrast with the embodiment of FIG. 4B below, where neighboring FET structures **311** may be coupled to gates **318** of the same word lines). As a result, each bit line may have two memory cells that are independently accessed. For example, bit line BL2 (FIG. 3A) may form part of FeFET **310B₁** and FeFET **310C₁**. Because each of the neighboring gates **318** are members of (e.g., attached to, coupled with) different word lines (e.g., WL1, WL2), the states of FeFET **310B₁** and FeFET **310C₁** may not be accessed together, and, therefore, may be independent of each other. Other groups of gates **318** may have neighboring gates **318** that are part of different word lines as well and may be configured in a similar manner. As a result, the memory array **300** may have greater capacity and/or higher density than the memory array **400** of FIGS. 4A and 4B described below.

Therefore, an apparatus may comprise a three-dimensional FeFET memory array having a plurality of bit lines and a plurality of word lines, wherein each bit line of the plurality of bit lines has at least two sides that are coupled with a ferroelectric material such that each bit line is shared by neighboring gates to form a plurality of FeFETs.

FIG. 4A is a perspective view of a schematic diagram of a memory array **400** according to another embodiment of the present disclosure. The memory array **400** includes a plurality of memory cells configured in a 3D structure that is generally similar to the memory array **300** of FIG. 3A. Thus, the majority of reference numerals and general construction of FIG. 4A remain the same as in FIG. 3A. The difference between FIG. 3A and FIG. 4A is in the configuration of the word lines.

As shown in FIG. 4A, the gates **318** that are parallel to each other in the x-y plane may be part of the same word line and receive the same voltage signal (e.g., by being coupled to a common contact). For example, the gates **318** that are labeled as WL1 may be coupled to a common contact such that they will receive the same voltage signal. Similarly, the gates **318** that are labeled as WL2 may be coupled to a common contact

such that they will receive the same voltage signal, the gates **318** that are labeled as WL3 may be coupled to a common contact such that they will receive the same voltage signal, and so on. Such contacts (not shown in FIG. 4A) may extend in the x-direction across an outer surface (or in some embodiments an intermediate position) of the memory array **400** and electrically couple with the corresponding gates **318**.

FIG. 4B is a top view of a portion of the memory array **400** of FIG. 4A. In particular, FIG. 4A shows the FeFETs **310A₁**-**310H₁**. As discussed above, each gate **318** that is parallel in the x-direction may be part of the same word line. If neighboring gates **318** are part of the same word line (WL), the FeFETs on each side of the same FET stack **311** may be accessed (e.g., written to, read from, etc.) together because they are part of the same bit line (BL) and the same word line (WL). For example, FeFET **310B₁** and **310C₁** may be accessed together if word line WL1 and bit line BL2 (FIG. 3A) are appropriately activated. Similarly, FeFET **310F₁** and **310G₁** may be accessed together when the appropriate voltages are applied to word line WL2 and bit line BL2 (FIG. 3A).

In other words, the state (i.e., polarization) of each FeFET that is coupled to the same bit line may not be independent of each other. As a result, a memory cell may be wasted in the sense that it cannot be independently accessed. Even though the ferroelectric material **320B** separates neighboring vertical FeFET stacks **305**, **306** and forms additional FeFETs **310B₁**, **310F₁**, it is almost as if the additional FeFETs **310B₁**, **310F₁** do not exist. In some embodiments, the ferroelectric material **320B** that separates neighboring vertical FeFET stacks **305**, **306** (and other similarly situated ferroelectric material **320D**, etc.) may be replaced by a dielectric material that is non-ferroelectric, which may not necessarily reduce the capacity of the memory array **400** because each bit line (BL) would effectively have one memory cell available.

Of course, there may still be some advantage to having the ferroelectric material **320B**, **320D** remain in such an embodiment that includes neighboring FeFETs to be accessed together. For example, the added redundancy may improve reliability. In such embodiments, the FeFET **310B₁** may serve as a replacement memory cell for FeFET **310C₁**, and vice versa. In other words, because FeFET **310B₁** and FeFET **310C₁** are accessed together, if one is defective the other may remain operational.

Embodiments of the present disclosure may include various contacting schemes for coupling the gates **318** of the word lines together. FIGS. 5 through 8 are top views of a schematic diagram of memory arrays showing various contacting schemes for the word line contacts. The word line contacts may be formed at the end (e.g., on top) of the 3D structure for the memory array; however, it is contemplated that one or more word line contacts may be buried within the 3D structure of the memory array. The memory arrays shown in FIGS. 5 through 8, in particular, have been simplified in order to focus the discussion on the contacting schemes. As a result, certain features (e.g., ferroelectric material, dielectric material, etc.) may not be depicted and/or labeled, but which may be otherwise be visible from such a view for the respective figure.

FIG. 5 shows a contacting scheme for a memory array **500** in which the gates **318** along the same x-axis are part of the same word line. For example, the memory array **500** may be configured similarly to the memory array **300** of FIG. 3A. In particular, the first group of gates **318** along the same x-axis may be part of word line WL1. Moving back in the z-direction, the second group of gates **318** that are parallel along the same x-axis may be part of word line WL2. Moving back yet

again in the z-direction, the third group of gates **318** that are parallel along the same x-axis may be part of word line WL3.

A first word line contact **502** extends along the memory array **500** such that the first word line contact **502** couples each of the gates **318** that are part of the first word line WL1. A second word line contact **504** extends along the memory array **500** such that the second word line contact **504** couples each of the gates **318** that are part of the second word line WL2. A third word line contact **506** extends along the memory array **500** such that the third word line contact **506** couples each of the gates **318** that are part of the third word line WL3, and so on. Each of the word line contacts **502**, **504**, **506** may be substantially linear and extend parallel to each other in the x-direction. In addition, each of the word line contacts **502**, **504**, **506** may be formed directly over its respective group of gates **318** that are part of the same word line.

As discussed above, if neighboring gates **318** are part of the same word line, the FeFETs formed on each side of the same bit line may be accessible together when each side of the bit line has a ferroelectric material associated therewith. As a result, neighboring FeFETs having a common bit line may not be independently accessible.

FIG. 6 shows a contacting scheme for a memory array **600** including a plurality of word lines. For example, the memory array **600** may be configured similarly to the memory array **400** of FIG. 4A. The gates **318** along the same x-axis may be part of different word lines. In particular, neighboring gates **318** may be part of the different word lines. For example, the first group of gates **318** along the same x-axis may be part of either word line WL1 or word line WL2. As shown in FIG. 6, the gates **318** may alternate between word line WL1 and word line WL2 moving in the x-direction. Moving back in the z-direction, the second group of gates **318** that are parallel along the same x-axis may be part of either word line WL3 or word line WL4. Moving back yet again in the z-direction, the third group of gates **318** that are parallel along the same x-axis may be part of either word line WL5 or word line WL6.

A first word line contact **602** extends along the memory array **600** such that the first word line contact **602** couples each of the gates **318** that are part of the first word line WL1. A second word line contact **604** extends along the memory array **600** such that the second word line contact **604** couples each of the gates **318** that are part of the second word line WL2. A third word line contact **606** extends along the memory array **600** such that the third word line contact **606** couples each of the gates **318** that are part of the third word line WL3. A fourth word line contact **608** extends along the memory array **600** such that the fourth word line contact **608** couples each of the gates **318** that are part of the fourth word line WL4. A fifth word line contact **610** extends along the memory array **600** such that the fifth word line contact **610** couples each of the gates **318** that are part of the fifth word line WL5. A sixth word line contact **612** extends along the memory array **600** such that the sixth word line contact **612** couples each of the gates **318** that are part of the sixth word line WL6, and so on. Each of the word line contacts **602**, **604**, **606**, **608**, **610**, **612** may extend across the memory array **600** having a curved (e.g., arcuate) shape to avoid contact with the neighboring gate **318**. For a group of gates **318** along the same x-axis, one word line contact (e.g., word line contacts **602**, **606**, **610**) may curve in a first direction around its neighboring gates **318**, while the other word line contact (e.g., word line contacts **604**, **608**, **612**) may curve in a second direction around its neighboring gates **318**.

As discussed above, if neighboring gates **318** are part of different word lines, the FeFETs formed on each side of the

11

same bit line may be independently accessible, which may provide for further density and/or capacity in the memory array **600**.

FIG. 7 shows a contacting scheme for a memory array **700** including a plurality of word lines. For example, the memory array **700** may be configured similarly to the memory array **400** of FIG. 4A. The gates **318** along the same x-axis may be part of different word lines. In particular, neighboring gates **318** may be part of the different word lines. For example, the first group of gates **318** along the same x-axis may be part of either word line WL1 or word line WL2. As shown in FIG. 7, the gates **318** may alternate between word line WL1 and word line WL2 moving in the x-direction. Moving back in the z-direction, the second group of gates **318** that are parallel along the same x-axis may be part of either word line WL3 or word line WL4. Moving back yet again in the z-direction, the third group of gates **318** that are parallel along the same x-axis may be part of either word line WL5 or word line WL6.

A first word line contact **702** extends along the memory array **700** such that the first word line contact **702** couples each of the gates **318** that are part of the first word line WL1. A second word line contact **704** extends along the memory array **700** such that the second word line contact **704** couples each of the gates **318** that are part of the second word line WL2. A third word line contact **706** extends along the memory array **700** such that the third word line contact **706** couples each of the gates **318** that are part of the third word line WL3. A fourth word line contact **708** extends along the memory array **700** such that the fourth word line contact **708** couples each of the gates **318** that are part of the fourth word line WL4. A fifth word line contact **710** extends along the memory array **700** such that the fifth word line contact **710** couples each of the gates **318** that are part of the fifth word line WL5. A sixth word line contact **712** extends along the memory array **700** such that the sixth word line contact **712** couples each of the gates **318** that are part of the sixth word line WL6, and so on. Each of the word line contacts **702**, **704**, **706**, **708**, **710**, **712** may be substantially linear and extend parallel to each other in the x-direction.

To avoid contact with the neighboring gate **318** within a group of gates **318** along the same x-axis, one word line contact (e.g., word line contacts **702**, **706**, **710**) may be offset from the gates **318** in a first direction, while the other word line contact (e.g., word line contacts **704**, **708**, **712**) may be offset from the gates **318** in a second direction. As a result, each of the word line contacts **702**, **704**, **706**, **708**, **710**, **712** may extend laterally in the z-direction beyond the respective gates **318** rather than aligning directly over the gates **318**. Having word line contacts **702**, **704**, **706**, **708**, **710**, **712** that are at least partially offset rather than extending directly over the gates **318** may increase the pitch of the memory array **700**. The increase in pitch, however, may be an appropriate tradeoff for increasing the number of independent memory cells per unit area.

As discussed above, if neighboring gates **318** are part of different word lines, the FeFETs formed on each side of the same bit line may be independently accessible, which may provide for further density and/or capacity in the memory array **700**.

FIG. 8 shows a contacting scheme for a memory array **800** that includes a plurality of word lines. The memory array **800** may be generally configured similarly to the memory array **400** of FIG. 4A. The difference between FIG. 8 and FIG. 4A is in the formation of word lines, and in particular, in the configuration of the gates **318**. For example, as with FIGS. 6 and 7, the gates **318** along the same x-axis may be part of different word lines. In particular, neighboring gates **318** may

12

be part of the different word lines. For example, the first group of gates **318** along the same x-axis may be part of either word line WL1 or word line WL2. The gates **318** may alternate between word line WL1 and word line WL2 when moving in the x-direction. Moving back in the z-direction, the second group of gates **318** that are parallel along the same x-axis may be part of either word line WL3 or word line WL4. Moving back yet again in the z-direction, the third group of gates **318** that are parallel along the same x-axis may be part of either word line WL5 or word line WL6.

A first word line contact **802** may extend along the memory array **800** such that the first word line contact **802** couples each of the gates **318** that are part of the first word line WL1. The first word line contact **802** may be substantially linear and may be formed directly over its respective group of gates **318** (similar to FIG. 5). As shown in FIG. 8, however, at least some of the gates **318** in the group in the same x-axis may not couple with the first word line contact **802**. In particular, neighboring gates **318** may not couple with the same word line contact **802**. Such neighboring gates **318** may be part of a different word line (e.g., word line WL2).

As an example, at least one gate **318** may not fully extend to the end (e.g., top) of the memory array **800** such that the gate **318** does not couple with the first word line contact **802**. For example, the gates **318** may alternate when moving along the x-direction, such that every other gate **318** may not extend to the end of the memory array **800**. As a result, every other gate **318** in the x-direction will be part of a different word line (e.g., word line WL2). Of course, other word line patterns are contemplated, including patterns that have more than two word lines in the same x-axis, as well as patterns that do not repeat.

Referring still to FIG. 8, the gate **318** that is part of word line WL2 may be coupled with a second word line contact **804** that is coupled to other gates **318** of the word line WL2. Because the memory array **800** is a three gate by three gate 3D memory array architecture, additional gates **318** coupled to word line WL2 are not shown. Such additional gates **318** may be present if the memory array **800** were larger. The second word line contact **804** coupled to the gates **318** of word line WL2 may be formed on the side of the memory array **800** that is opposite the first word line contact **802**. The gates **318** of the first word line WL1 may not couple with the second word line contact **804**. For example, the gates **318** of the first word line WL1 may not fully extend to the end (e.g., bottom) of the memory array **800** such that the gate **318** does not couple with the second word line contact **804**. Similarly, the gates **318** of the second word line WL2 may not couple with the first word line contact **802**.

Additional word line contacts (not shown) may be coupled to the gates **318** of additional word lines (e.g., word lines WL3, WL4, WL5, WL6) of the memory array **800**. Such additional word line contacts may extend parallel to each other in the x-direction and lay in the x-y plane. According to the embodiment of FIG. 8, gates **318** for odd word lines (e.g., word lines WL3, WL5) may extend to the top of the memory array **800** such that the odd word lines (e.g., word lines WL3, WL5) couple with word line contacts (not shown) that extend along the top of the memory array **800**. Gates **318** for even word lines (e.g., word lines WL4, WL6) may not extend fully to the top of the memory array **800** such that the even word lines (e.g., word lines WL4, WL6) may not couple with the word line contacts (not shown) that extend along the top of the memory array **800**. Similarly, gates **318** for even word lines (e.g., word lines WL4, WL6) may extend to the bottom of the memory array **800** such that the even word lines (e.g., word lines WL4, WL6) couple with word line contacts (not shown)

13

that extend along the bottom of the memory array **800**. Gates **318** for odd word lines (e.g., word lines WL3, WL5) may not extend fully to the bottom of the memory array **800** such that the odd word lines (e.g., word lines WL3, WL5) may not couple with the word line contacts (not shown) that extend along the bottom of the memory array **800**.

As discussed above, if neighboring gates **318** are part of different word lines, the FeFETs formed on each side of the same bit line may be independently accessible, which may provide for further density and/or capacity in the memory array **800**.

In some embodiments, an apparatus may comprise a FeFET memory array having a plurality of FeFETs coupled at cross-points of a plurality of access lines. The FeFET memory array may be configured to have a substantially uniform series resistance for a current path regardless of which FeFET of the plurality of FeFETs is selected.

FIG. 9 is a perspective view of a portion of a memory array **900**. In particular, the portion of the memory array **900** may include a single FET structure **311** coupled to a ferroelectric material **320** and a plurality of gates **318**. The portion of the memory array **900** may be part of a 3D memory array architecture, such as those described above with respect to FIGS. 3A through 8. Therefore, the memory array **900** may include additional FET structures **311** stacked in the various directions needed to form the 3D architecture. For the portion of the memory array **900** shown in FIG. 9, three FeFETs are formed (by the three gates **318** coupled to the FET structure **311** with the ferroelectric material **320**); however, the memory array **900** may include additional elements such that any number of FeFETs may be used as memory cells.

In operation, an appropriate combination of voltages may be applied to the contacts (not shown) for the gate **318**, source region (source line) **314** and drain region (bit line) **312** in order to access (e.g., sense) the memory cell to determine a state of the memory cell. Current **902** may flow through the bit line **312** and to the source line **314** at the location of the gate **318** receiving an appropriate voltage **901**. The current **902** from the source line **314** may be sensed to determine the polarity of the ferroelectric material **320** at the location of the gate **318**. As discussed above, the bit line **312** may be coupled to a bit line contact (not shown) and the source line **314** may be coupled to a source line contact (not shown). The bit line contact and the source line contact may be coupled to the respective bit line **312** and source line **314** on opposite ends of the memory array **900**. For example, the bit line **312** may couple to the bit line contact at a first end **950** of the memory array **900** (where the arrow representing the current **902** begins). The source line **314** may couple to the source line contact at a second end **952** of the memory array **900** (where the arrow representing the current **902** ends).

With the source line contact and the bit line contact being coupled on opposing ends of the memory array **900**, the total path for the current **902** may be approximately the same distance regardless of which word line is accessed. For example, the path for the current **902** may be approximately the same distance if any of word lines WL1, WL2, WL3 are activated. As a result, the series resistance for the current **902** is approximately the same regardless of which memory cell is activated.

During a read operation, when the threshold voltage of the selected memory cell is sensed, substantially the same threshold is sensed for a given state (e.g., 0 or 1) regardless of where the memory cell is located in the memory array **900**. In contrast with FIGS. 1A and 1B, conventional two-dimensional memory arrays may have the bit line and source line contacts on the same end of the memory array. As a result, the

14

series resistance may not be uniform for accessing each memory cell of the memory array, and the threshold voltage for a selected cell will be different depending on the location in the memory array. Therefore, embodiments of the present disclosure that include contacts on opposing sides of the array may be less variable in sensing the threshold voltage during read operations in comparison with conventional two-dimensional memory arrays.

FIG. 10 is a schematic circuit diagram of a portion of a memory array **1000** according to an embodiment of the present disclosure. The memory array **1000** may include memory cells configured as FeFETs that are located at cross-points of word lines (WL) and bit lines (BL). The physical structure of the memory array **1000** may have a 3D memory array architecture, as discussed above.

As shown in FIG. 10, during an access of a memory cell **1010** of the memory array **1000**, a current **1002** may flow from one end of the memory array **1000** to another end of the memory array **1000**. Thus, the contacts for the bit lines (BL1-BL6) and source lines (SL1-SL6) may be coupled to opposite ends of the memory array **1000**. As a result, the path for the current **1002** may have a uniform series resistance regardless on which memory cell is accessed.

The three-dimensional memory arrays described herein may be included within an apparatus. The apparatus may include a first vertical FeFET stack including a first plurality of gates that are separated from a first vertical FeFET stack by a first ferroelectric material, and a second vertical FeFET stack including a second plurality of gates that are separated from a second vertical FeFET stack by a second ferroelectric material, wherein the first vertical FeFET stack and the second FeFET stack are stacked horizontally and separated by a dielectric material.

The apparatus may further comprise a memory device including the three-dimensional memory array. The apparatus may further comprise an electrical system including the memory device. The apparatus may further comprise a control circuit operably coupled to the memory device, and configured to apply one or more voltages to perform operations on memory cells of the first vertical FeFET stack and the second vertical FeFET stack. The apparatus may further comprise an input device and an output device operably coupled to the control circuit.

FIG. 11 is a perspective view of a schematic diagram of a portion of a memory array **1100** according to another embodiment of the present disclosure. The memory array **1100** may be configured in a 3D-NAND type configuration, in which a plurality of vertical strings **1104₁**, **1104₂**, **1104₃** of memory cells are formed on a substrate **1102**. Each vertical string **1104₁**, **1104₂**, **1104₃** may be coupled to an upper select gate **1106** (e.g., drain select gate) on a first end and to a lower select gate **1108** (e.g., source select gate) on a second end. The memory array **1100** may include a plurality of memory cell gates **1107** coupled with the vertical strings **1104₁**, **1104₂**, **1104₃** between the upper select gate **1106** and the lower select gate **1108**. As a result, the vertical strings **1104₁**, **1104₂**, **1104₃** may extend vertically and orthogonal to the upper select gate **1106**, the memory cell gates **1107**, and the lower select gate **1108**. The upper select gate **1106**, the memory cell gates **1107**, and the lower select gate **1108** may be separated by an insulation material **1101**, such as a dielectric material (e.g., oxide).

Each vertical string **1104₁**, **1104₂**, **1104₃** may include a vertical channel **1116** that passes through, and couples with, the upper select gate **1106**, the lower select gate **1108**, and the memory cell gates **1107** therebetween. The vertical channel **1116** may be formed of poly-silicon. The vertical channels

15

1116 may be surrounded by a ferroelectric material **1120**. As a result, individual FeFET memory cells may be formed at the intersection of the vertical channel **1116** and the memory cell gate **1107**. The memory cell gates **1107** may be coupled to different word lines WL1, WL2, WL3 to select a particular row of the memory array **1100**. The vertical channels **1116** may be coupled to a bit line BL1, BL2, BL3 through an N diffusion region to select a particular column of the memory array **1100**. The substrate **1102** may be coupled to a source line. In operation, when a memory cell is accessed, the ferroelectric material at the selected intersection may exhibit a polarization that is interpreted as the state of the memory cell as described above.

The memory array **1100** of FIG. **11** is a simplified schematic diagram, and it should be recognized that additional elements may be coupled therewith to facilitate operation thereof. For example, access lines (e.g., word lines, bit lines, select lines) and other contact elements may be coupled with the memory array **1100** for applying voltages to the various elements of the memory array **1100** to perform operations (e.g., read, write, erase, etc.) thereon. For example, select lines may be coupled with the select gates **1106**, **1108**. Word lines may be coupled with the memory cell gates **1107**, and bit lines may be coupled with the vertical strings **1104₁**, **1104₂**, **1104₃**. The memory array **1100** may also include a control unit (not shown) that is coupled with the select gates **1106**, **1108**, the memory cell gates **1107**, and the vertical strings **1104₁**, **1104₂**, **1104₃**. Such a control unit may include at least one of string driver circuitry, pass gates, circuitry for selecting gates, circuitry for selecting conductive lines (e.g., bit lines, word lines), circuitry for amplifying signals, and circuitry for sensing signals.

Although the memory array **1100** only shows FeFET memory cells in a single x-y plane, showing such a 2D portion of the memory array **1100** may be for convenience of illustration. The memory array **1100** may be a 3D memory array **1100**. For example, each of the select gates **1106**, **1108**, the memory cell gates **1107**, substrate **1102**, and insulation material **1101** may extend into the z-direction such that additional vertical strings may be formed at additional locations along the z-direction such that a 3D structure (e.g., cube, cuboid) is formed. In other words, the select gates **1106**, **1108** and the memory cell gates **1107** may be configured as conductive plates that are substantially planar, such that an array of vertical strings may pass through openings (e.g., holes) formed through the conductive plates for coupling therewith.

FIG. **12** is a simplified block diagram of an electrical system **1200** including a vertical memory cell. The electrical system **1200** may include a memory array **1210**, a control circuit **1220**, an input device **1230**, and an output device **1240** that are operably coupled to communicate with each other through the control circuit **1220**. The memory array **1210** may include a plurality of memory cells configured as FeFETs and arranged in a 3D architecture. In general, the memory array **1210** may include any combination of features of the memory arrays described herein, and their equivalents. The memory array **1210** may be included within a memory device, a semiconductor wafer, or other similar apparatus.

The control circuit **1220** may be configured to control the memory array **1210**. The control circuit **1220** may include one or more device from the group consisting of a processor, a hard disk drive, and an optical disc drive (not shown). The control circuit **1220** may be operably coupled to the bit lines **312** (FIG. **9**), the source lines **314** (FIG. **9**), and the gates **318** (FIG. **9**) in order to perform desired operations (e.g., read, write, erase) on the memory array **1210**.

16

The control circuit **1220** may also be operably coupled to the input device **1230**, and the output device **1240**. By way of non-limiting example, the input device **1230** may include any of a keyboard, a button array, a mouse device, a touch screen input, other similar devices, and combinations thereof. The control circuit **1220** may be configured to receive and execute commands, and receive information, from the input device **1230**.

The output device **1240** may include, by way of non-limiting example, any of a liquid crystal display (LCD) device, a light emitting diode (LED) array, a cathode ray tube (CRT) display, a sound generating device, an electrical signal output port, other similar devices, and combinations thereof. The control circuit **1220** may be configured to cause the output device **1240** to communicate information to a user (not shown) or another device (not shown).

While certain illustrative embodiments have been described in connection with the figures, those of ordinary skill in the art will recognize and appreciate that embodiments encompassed by the disclosure are not limited to those embodiments explicitly shown and described herein. Rather, many additions, deletions, and modifications to the embodiments described herein may be made without departing from the scope of embodiments encompassed by the disclosure, such as those hereinafter claimed, including legal equivalents. In addition, features from one disclosed embodiment may be combined with features of another disclosed embodiment while still being encompassed within the scope of the disclosure as contemplated by the inventors.

What is claimed is:

1. An apparatus, comprising:

a plurality of field-effect transistor (FET) structures stacked horizontally and vertically in a three-dimensional memory array architecture;

a plurality of gates extending vertically and spaced horizontally between the plurality of FET structures; and

a ferroelectric material separating the plurality of FET structures and the plurality of gates, wherein:

individual ferroelectric FETs (FeFETs) are located at intersections of the plurality of FET structures, the plurality of gates, and the ferroelectric material; and the ferroelectric material is shared by FeFETs of a same vertical FeFET stack.

2. The apparatus of claim 1, wherein each FET structure of the plurality of FET structures includes a drain region, a body region, and a source region stacked in a vertical arrangement.

3. The apparatus of claim 2, further comprising a plurality of access lines coupled with individual FeFETs.

4. The apparatus of claim 3, wherein the plurality of access lines includes:

a plurality of word lines coupled to the plurality of gates; and

a plurality of bit lines coupled to the drain regions of the plurality of FET structures.

5. The apparatus of claim 4, wherein the plurality of word lines couple to the plurality of gates according to an alternating contact scheme.

6. The apparatus of claim 2, wherein each FET structure further comprises:

a drain contact coupled to the drain region; and

a source contact coupled to the source region, wherein the drain contact and the source contact are coupled on opposite ends of the three-dimensional memory array architecture.

7. The apparatus of claim 6, wherein the source contact is further coupled to the body region of the corresponding FET structure.

17

8. The apparatus of claim 1, wherein each gate of the plurality of gates has the ferroelectric material disposed on at least one side of the gate.

9. The apparatus of claim 1, wherein at least some of the gates of the plurality of gates have the ferroelectric material disposed on at least two sides of the gate.

10. An apparatus, comprising:

a first vertical ferroelectric field-effect transistor (FeFET) stack including a first plurality of gates separated from a first FET structure by a first ferroelectric material; and a second vertical FeFET stack including a second plurality of gates separated from a second FET structure by a second ferroelectric material, wherein:

the first vertical FeFET stack and the second vertical FeFET stack are stacked horizontally and separated by a dielectric material; and

the first ferroelectric material is shared by FeFETs of the first vertical FeFET stack and the second ferroelectric material is shared by FeFETs of the second vertical FeFET stack.

11. The apparatus of claim 10, wherein the dielectric material includes a third ferroelectric material configured such that the second vertical FeFET stack has memory cells on both sides of the second FET structure of the second vertical FeFET stack.

12. The apparatus of claim 11, wherein neighboring gates from the first plurality of gates and the second plurality of gates along the same horizontal axis are part of the same word line.

13. The apparatus of claim 12, further comprising a plurality of word line parallel contacts that extend linearly across the first vertical FeFET stack and the second vertical FeFET stack, wherein a single word line contact couples the neighboring gates from the first plurality of gates and the second plurality of gates along the same horizontal axis.

14. The apparatus of claim 11, wherein neighboring gates from the first plurality of gates and the second plurality of gates along the same horizontal axis are part of different word lines.

15. The apparatus of claim 14, further comprising a plurality of additional vertical FeFET stacks that include additional pluralities of gates, the additional vertical FeFET stacks stacked horizontally with the first vertical FeFET stack and the second vertical FeFET stack.

16. The apparatus of claim 15, further comprising a plurality of mutually parallel word line contacts that extend along the first vertical FeFET stack, the second vertical FeFET stack, and the plurality of additional vertical FeFET stacks, wherein neighboring gates from the first plurality of gates and the second plurality of gates along the same horizontal axis couple to different ones of the mutually parallel word line contacts.

17. The apparatus of claim 16, wherein:

one of the neighboring gates extends to a first end of the first vertical FeFET stack, and couples with a first one of the mutually word line contact; and

another of the neighboring gates extends to a second end of the second vertical FeFET stack, and couples with a second one of the mutually word line contact.

18. The apparatus of claim 16, wherein the plurality of word line contacts are offset from the first plurality of gates and the second plurality of gates, and further extend linearly across the first vertical FeFET stack, the second vertical FeFET stack, and the plurality of additional vertical FeFET stacks.

18

19. The apparatus of claim 16, wherein the plurality of word line contacts each has an arcuate shape that extends around one of the neighboring gates.

20. The apparatus of claim 10, wherein the first vertical FeFET stack and the second vertical FeFET stack comprise a portion of a three dimensional memory array of the apparatus.

21. The apparatus of claim 20, wherein the three-dimensional memory array comprises at least a portion of a memory device of the apparatus.

22. The apparatus of claim 21, wherein the memory device comprises at least a portion of the apparatus.

23. The apparatus of claim 22, further comprising a control circuit operably coupled to the memory device, and configured to apply one or more voltages to perform operations on memory cells of the first vertical FeFET stack and the second vertical FeFET stack.

24. The apparatus of claim 23, further comprising an input device and an output device operably coupled to the control circuit.

25. An apparatus, comprising:

a ferroelectric field-effect transistor (FeFET) memory array having a plurality of FeFETs coupled at cross-points of a plurality of access lines, wherein the FeFET memory array is configured to have a substantially uniform series resistance for a current path for each FeFET of the plurality of FeFETs.

26. The apparatus of claim 25, further comprising:

a plurality of bit line contacts coupled to bit lines of the plurality of FeFETs;

a plurality of source line contacts coupled to source lines of the plurality of FeFETs; and

a plurality of word line contacts coupled to word lines of the plurality of FeFETs, wherein the bit line contacts and the source line contacts are coupled on opposing ends of the FeFET memory array.

27. An apparatus, comprising:

a three-dimensional memory array having a plurality of ferroelectric field-effect transistor (FeFET) memory cells located at intersections of ferroelectric material coupled with a plurality of bit lines and a plurality of word lines, wherein:

the plurality of FeFET memory cells are located along vertical strings of the three-dimensional memory array; and

the ferroelectric material is shared by the plurality of FeFET memory cells along the vertical strings.

28. The apparatus of claim 27, wherein each bit line of the plurality of bit lines are coupled to a drain region that has at least two sides coupled with the ferroelectric material such that each drain region is shared by neighboring gates to form the plurality of FeFET memory cells.

29. The apparatus of claim 28, wherein the neighboring gates and word lines are configured to independently access the plurality of FeFETs associated with the same bit line.

30. The apparatus of claim 27, wherein the vertical strings couple with memory cell gates coupled with the plurality of word lines.

31. The apparatus of claim 30, wherein the vertical strings each include a vertical channel surrounded by the ferroelectric material.

32. A method of operating a three-dimensional ferroelectric field-effect transistor (FeFET) memory array, the method comprising:

applying a combination of voltages to a plurality of word lines and digit lines for a desired operation for a plurality of FeFET memory cells of a three-dimensional FeFET memory array, at least one digit line having a plurality of

FeFET memory cells accessible by neighboring gates through shared ferroelectric material.

33. The method of claim **32**, wherein applying a combination of voltages comprises employing a selection scheme from the group consisting of a $V/3$ selection scheme and a $V/2$ selection scheme.

* * * * *

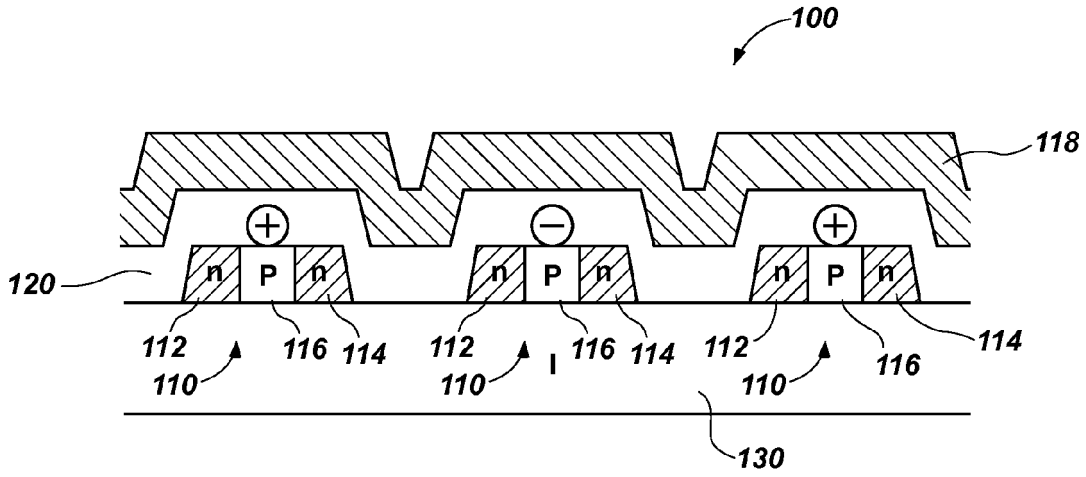

FIG. 1A
(PRIOR ART)

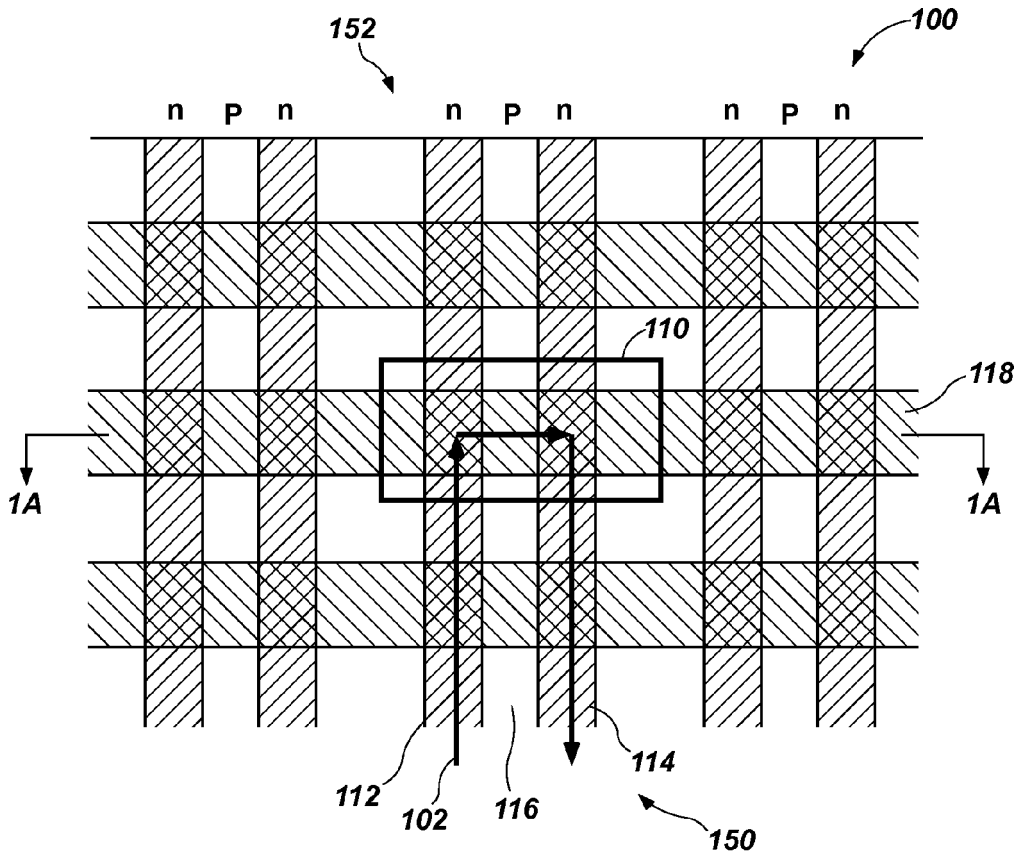

FIG. 1B
(PRIOR ART)

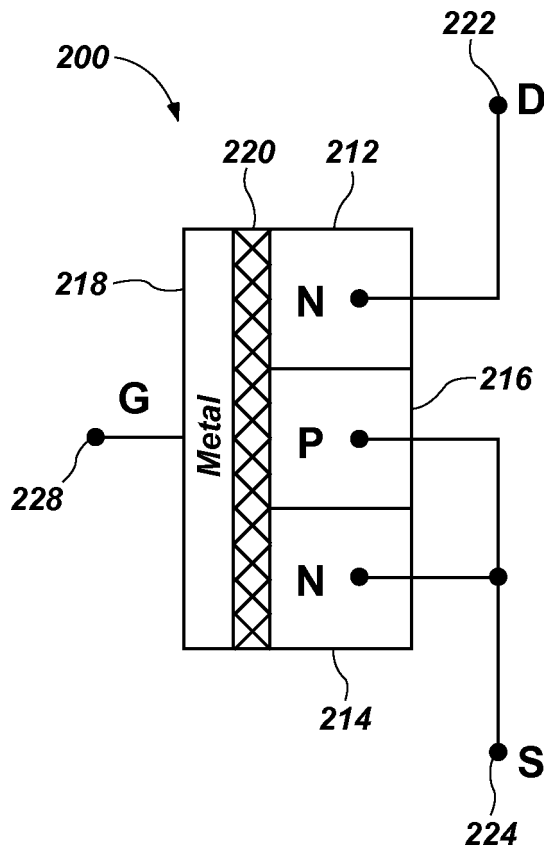

FIG. 2

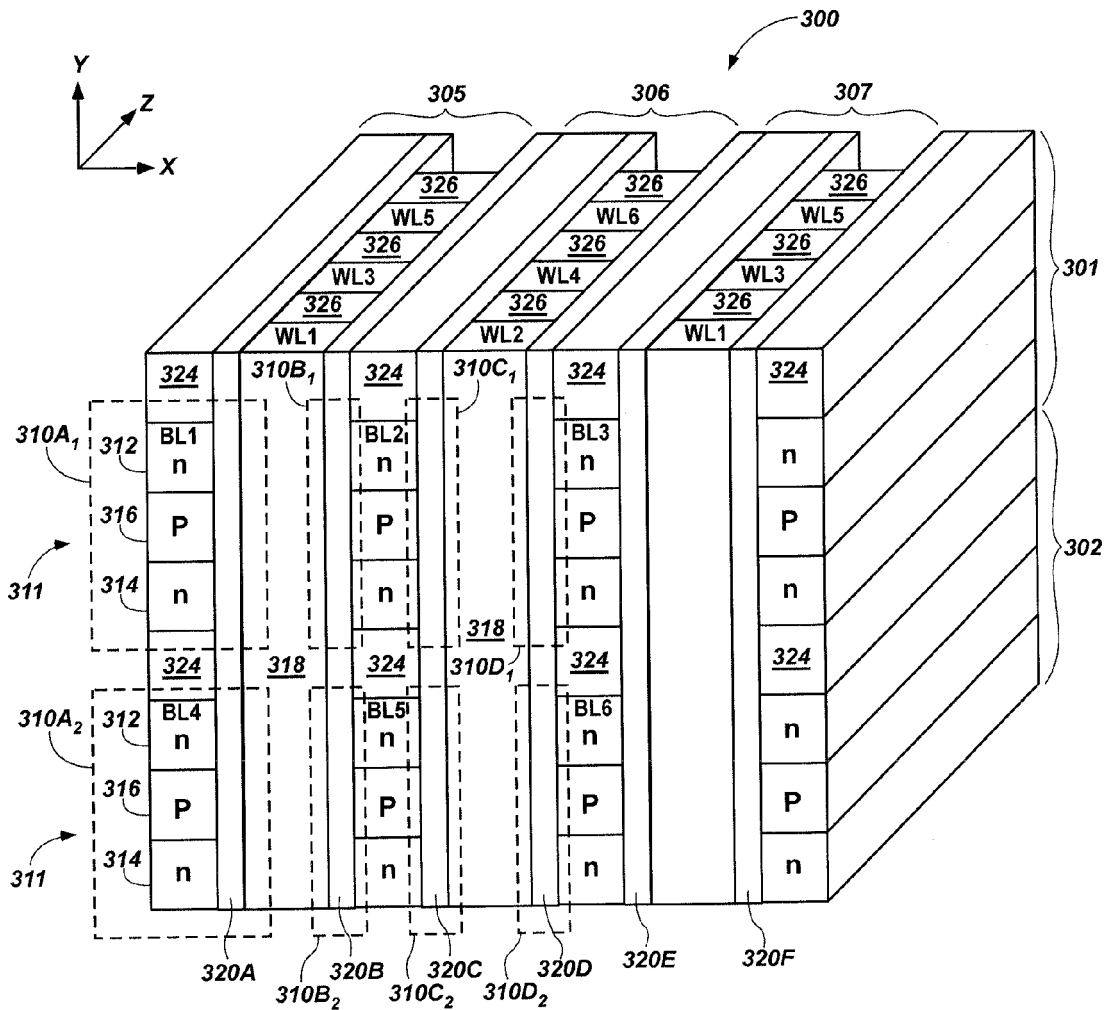

FIG. 3A

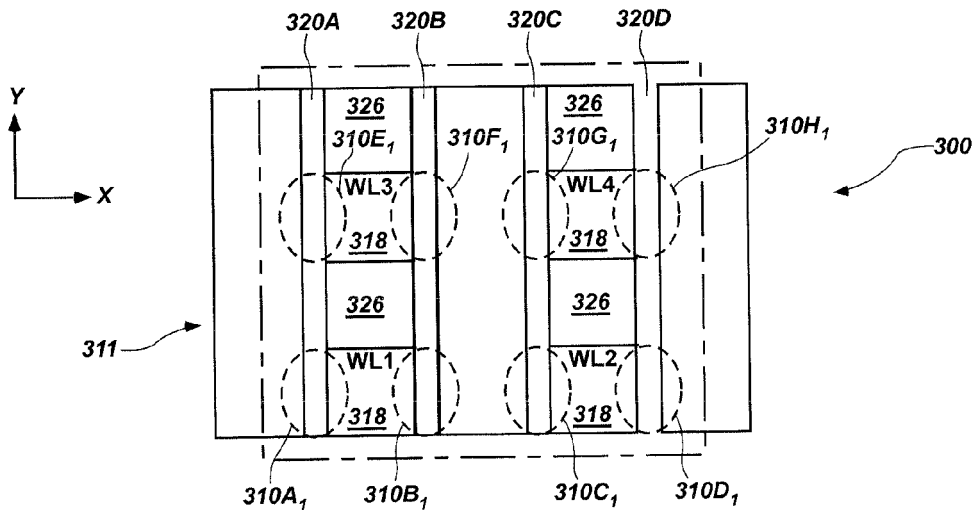

FIG. 3B

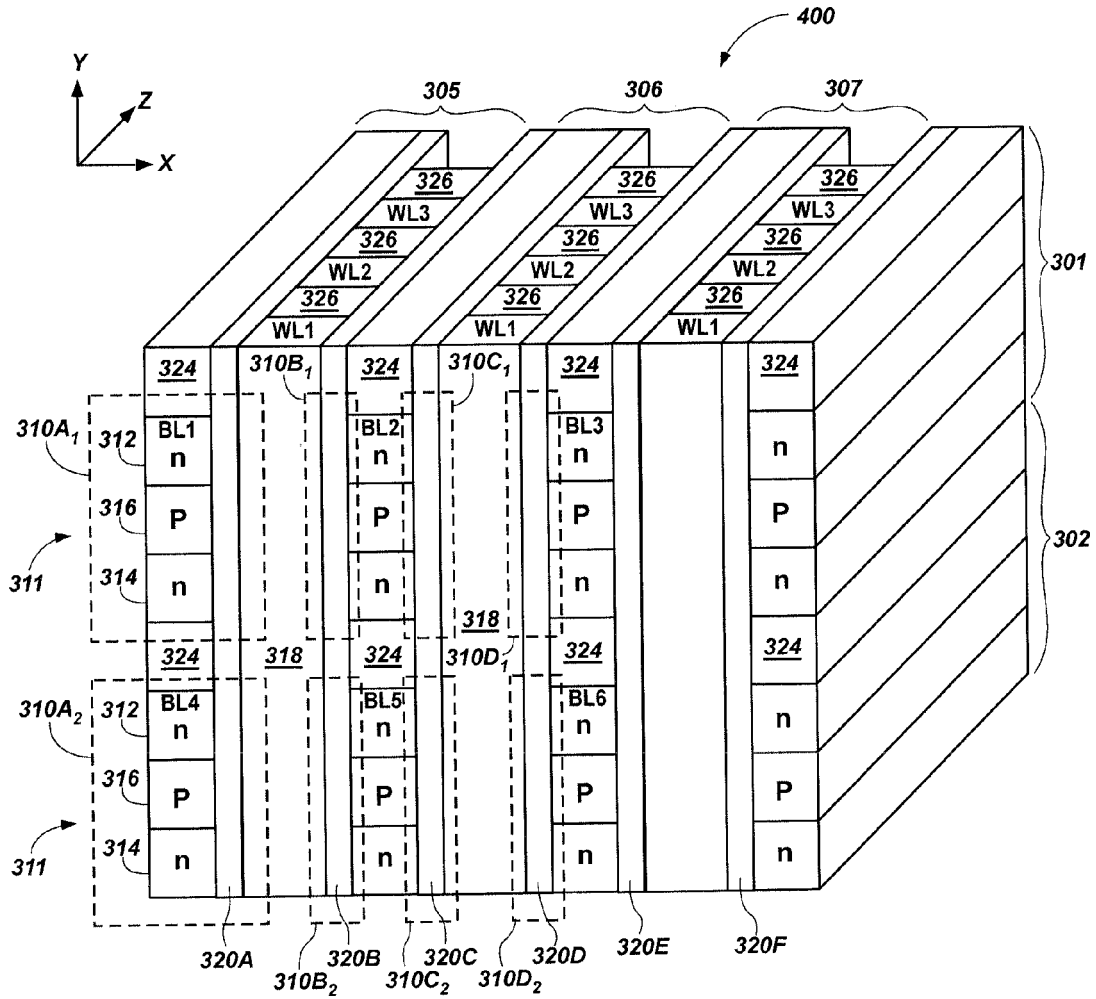

FIG. 4A

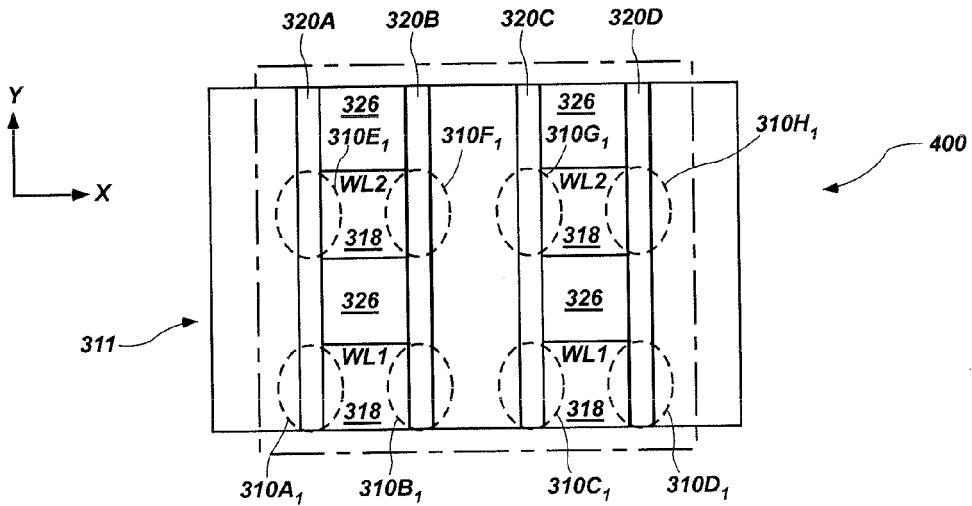

FIG. 4B

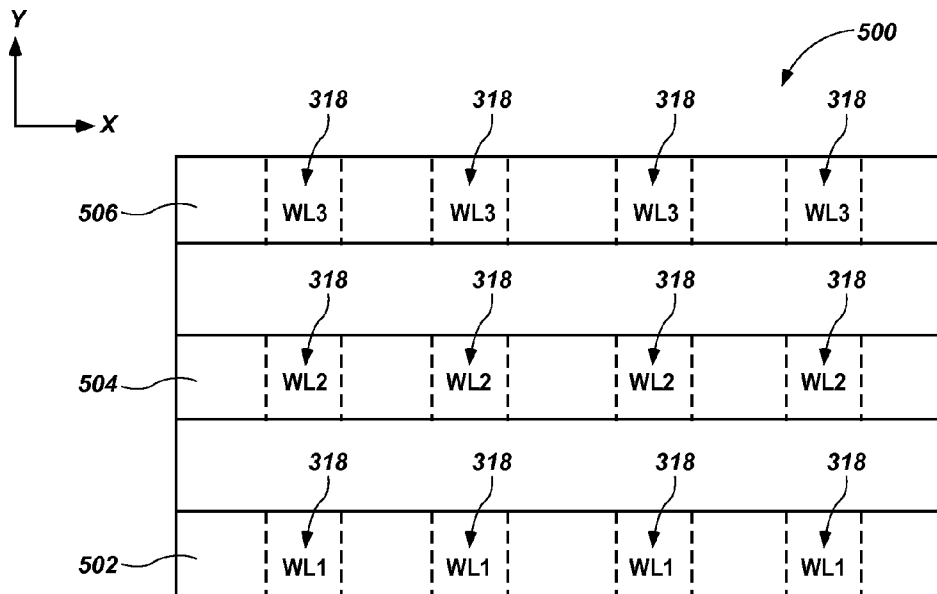

FIG. 5

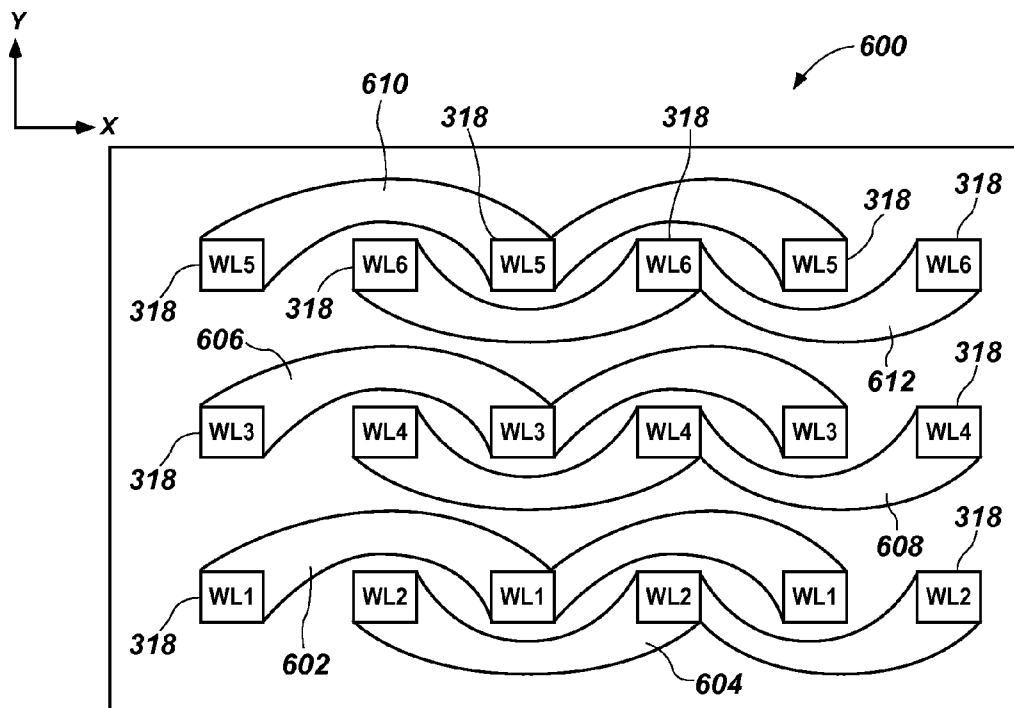

FIG. 6

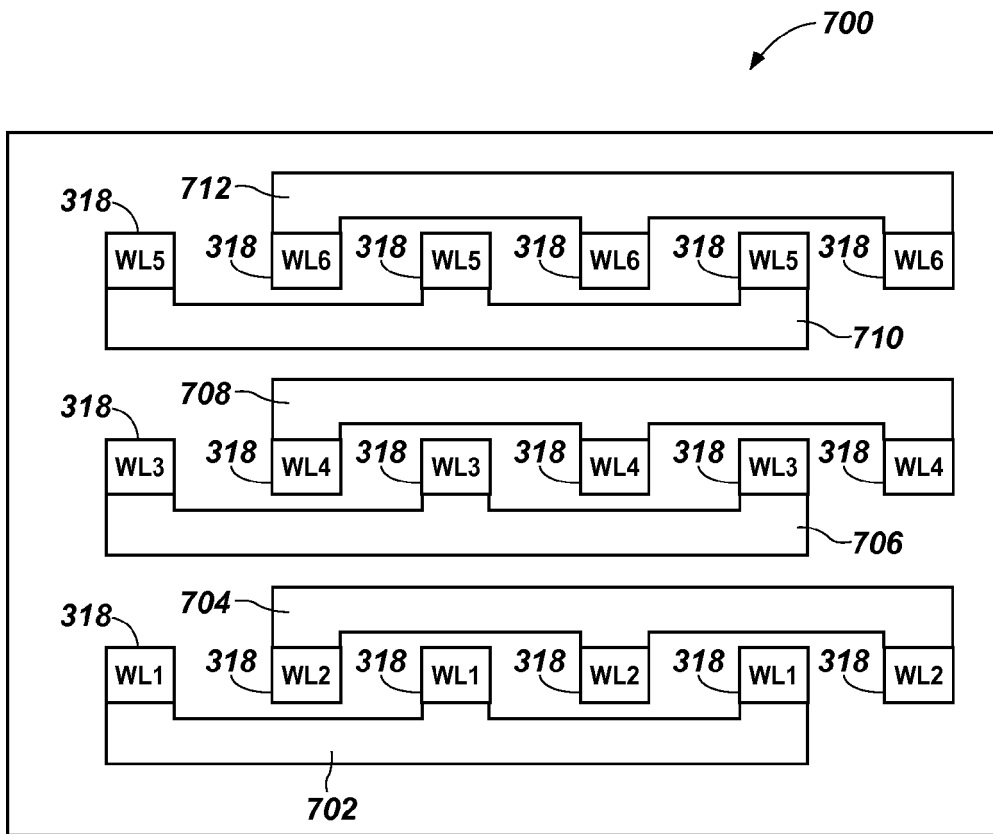

FIG. 7

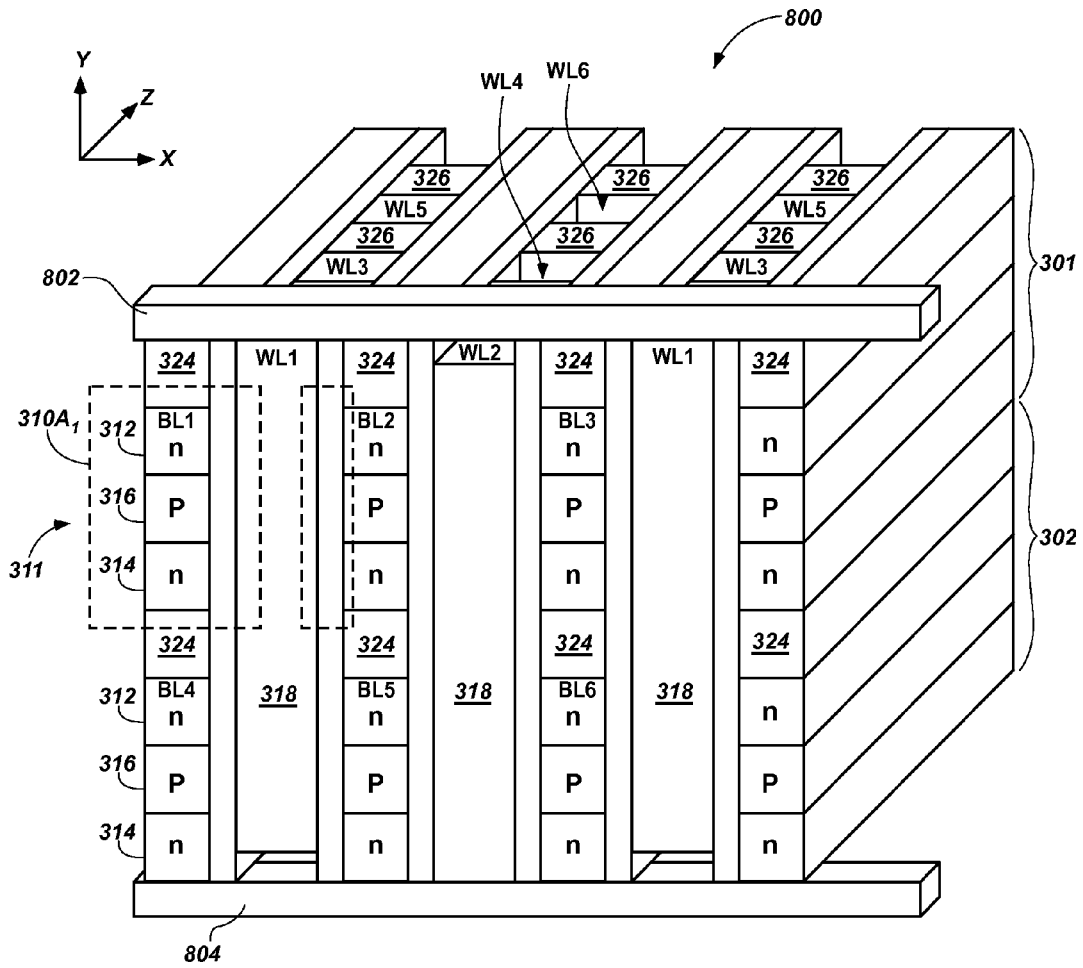

FIG. 8

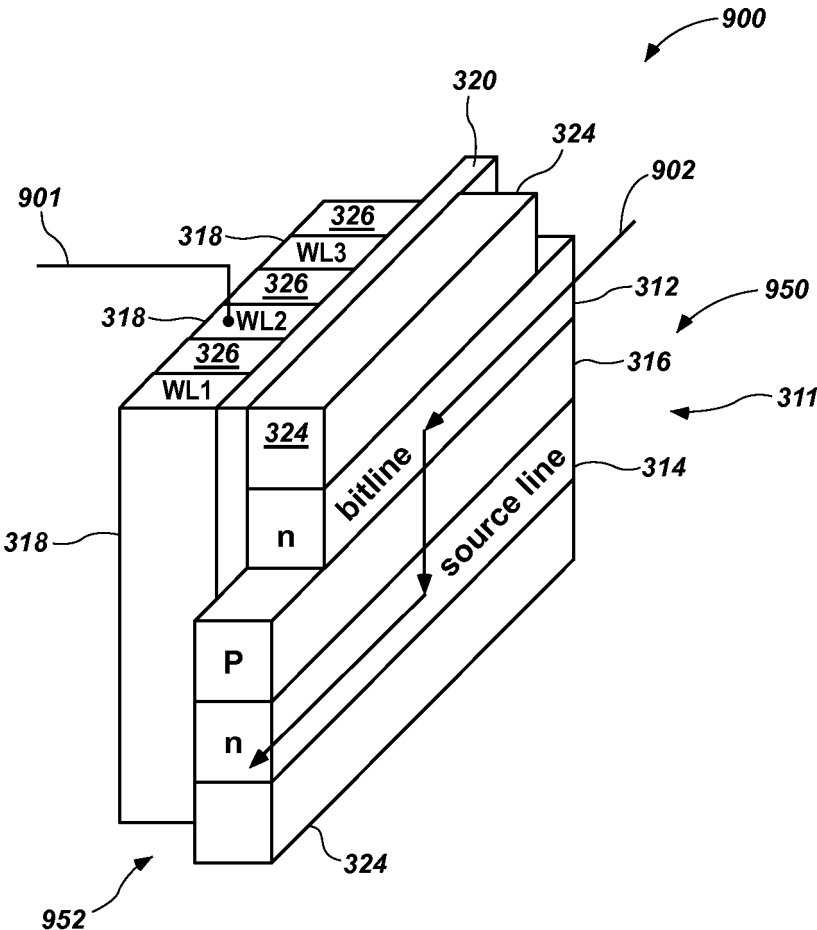

FIG. 9

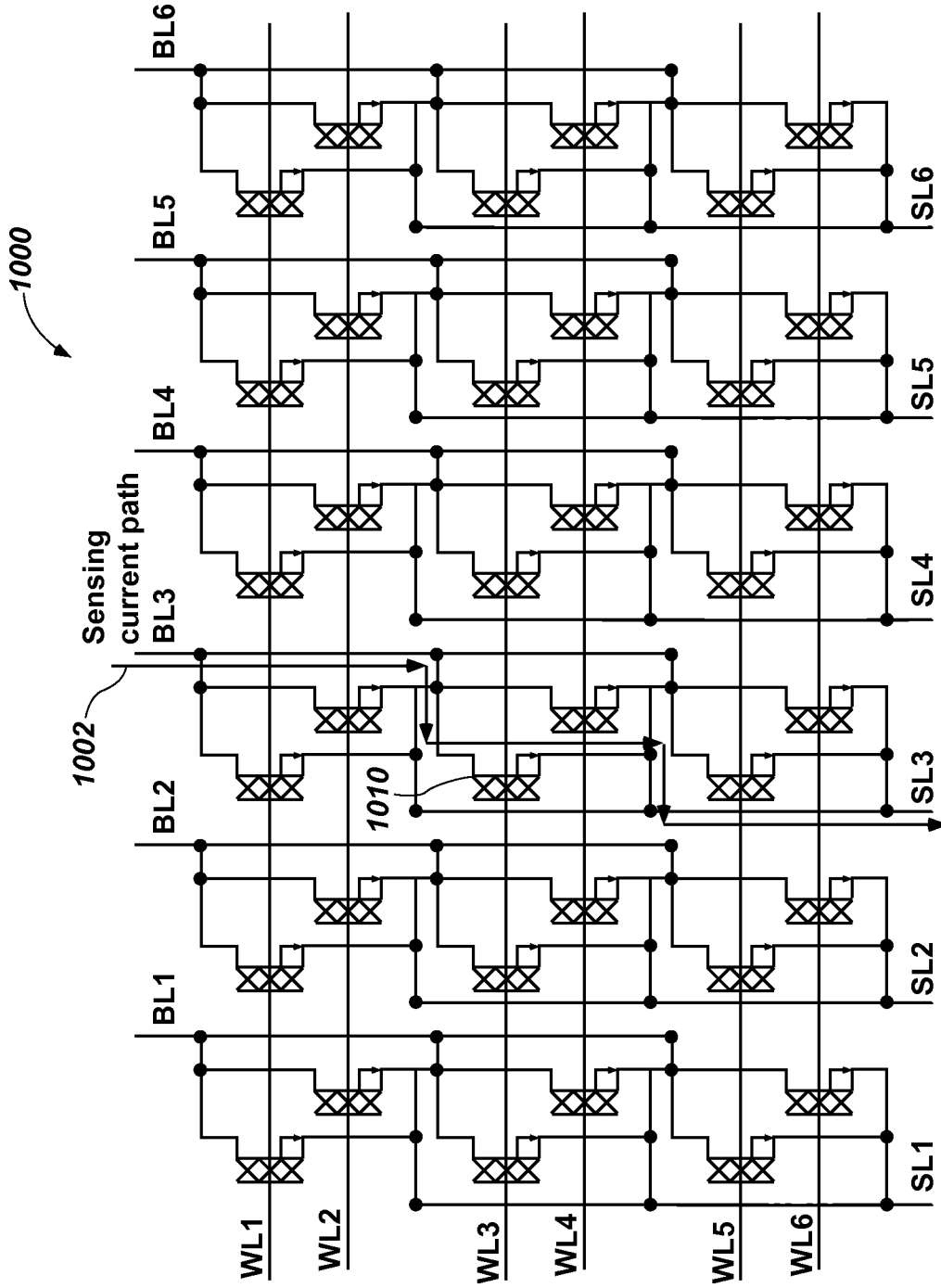

FIG. 10

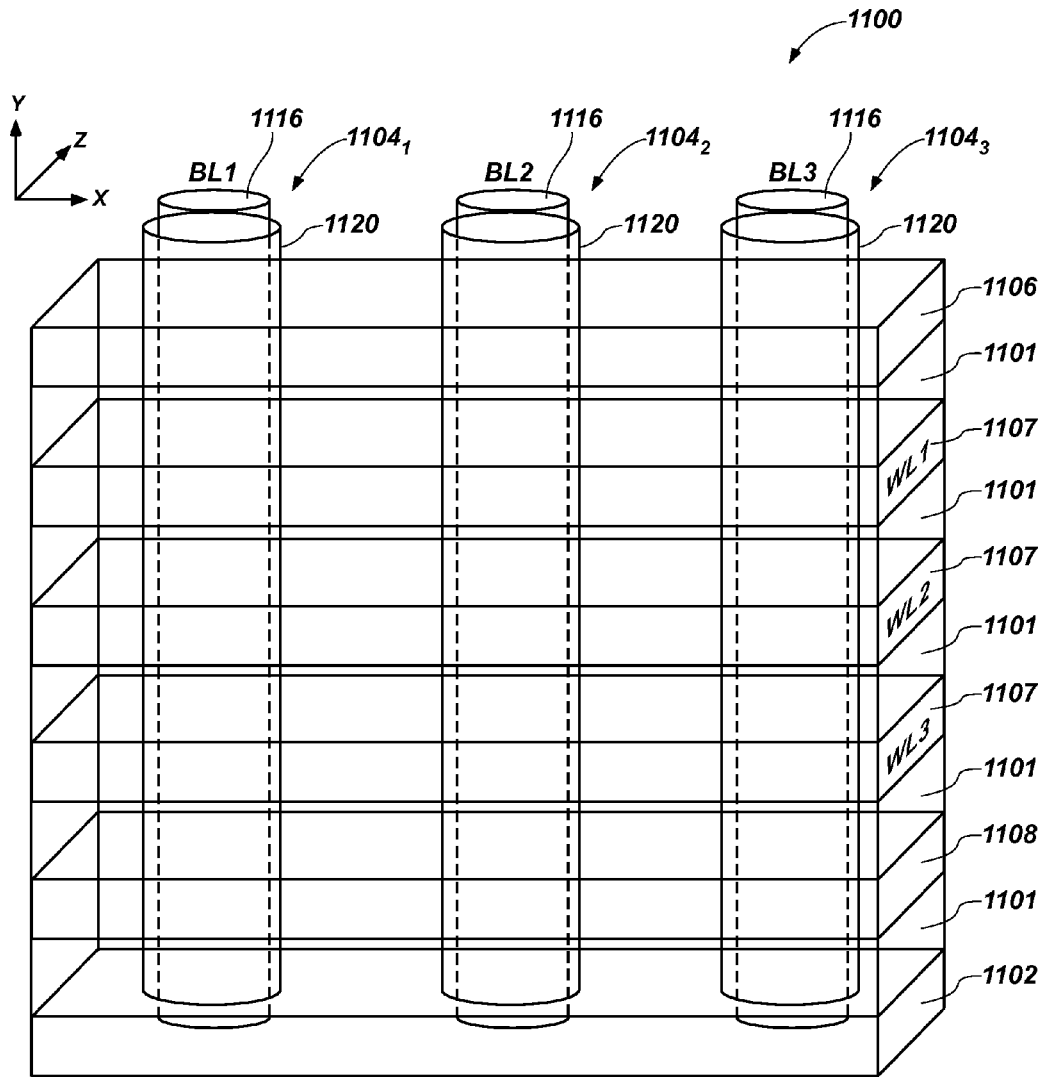

FIG. 11

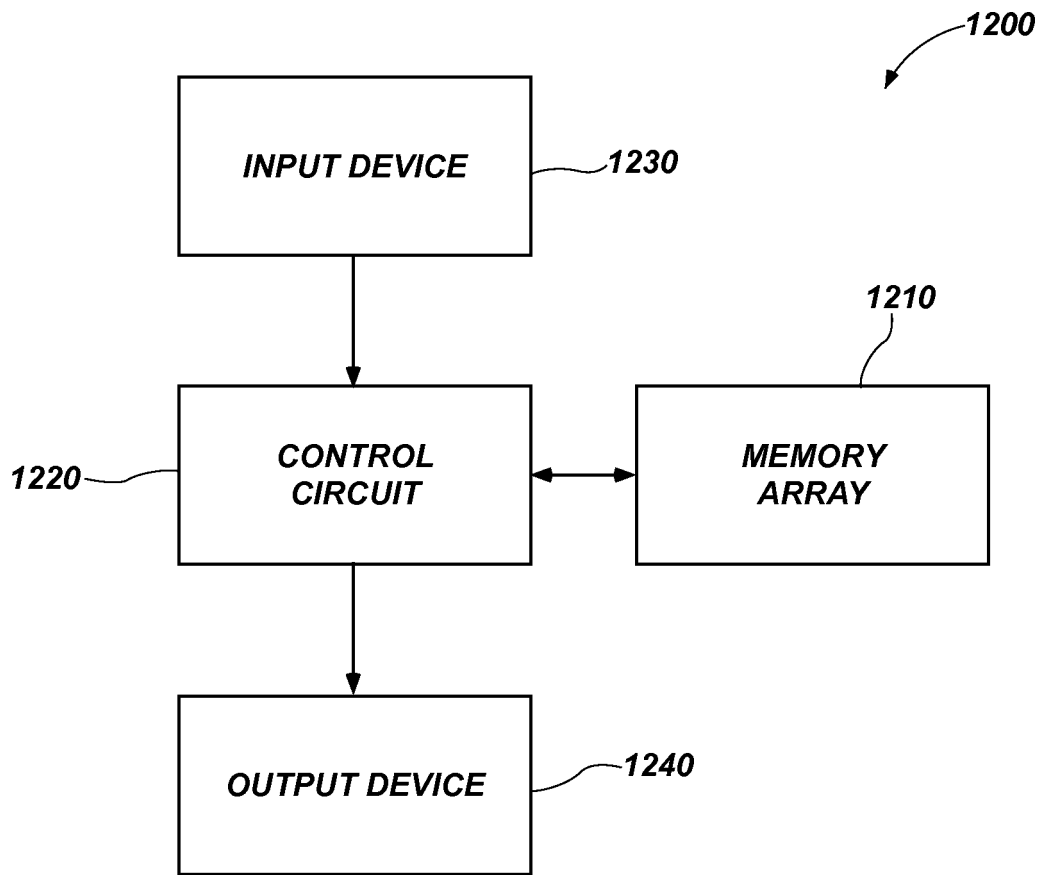

FIG. 12

UNITED STATES PATENT AND TRADEMARK OFFICE
CERTIFICATE OF CORRECTION

PATENT NO. : 9,281,044 B2
APPLICATION NO. : 13/897037
DATED : March 8, 2016
INVENTOR(S) : D. V. Nirmal Ramaswamy et al.

Page 1 of 1

It is certified that error appears in the above-identified patent and that said Letters Patent is hereby corrected as shown below:

On the title page:

In ITEM (57) **ABSTRACT:**

LINE 11, change "to faun a" to --to form a--

In the specification:

COLUMN 4, LINE 51, change "'0," as long" to --"0," as long--
COLUMN 15, LINE 17, change "thereof For" to --thereof. The--
COLUMN 16, LINE 5, change "thereof For" to --thereof. The--

In the claims:

CLAIM 2, COLUMN 16, LINE 46, change "verticalarrangement." to --vertical
arrangement.--
CLAIM 20, COLUMN 18, LINE 6, change "three dimensional" to --three-dimensional--
CLAIM 24, COLUMN 18, LINE 17, change "he apparatus" to --The apparatus--

Signed and Sealed this
Seventeenth Day of May, 2016

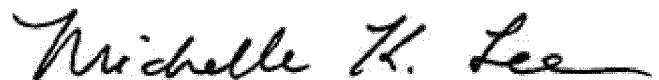

Michelle K. Lee
Director of the United States Patent and Trademark Office